

**MICROWAVE ENGINEERING
LABORATORY MANUAL (ECE - 424)
IV/IV ECE SEM - I**



By

Mr. Vijay Kumar Sahu
Assistant Professor, ECE

Dr. V. Rajya Lakshmi
Professor & HOD, ECE

DEPARTMENT OF ELECTRONICS AND COMMUNICATION ENGINEERING

ANIL NEERUKONDA INSTITUTE OF TECHNOLOGY & SCIENCES (A)
(Affiliated to AU, Approved by AICTE & Accredited by NBA) Sangivalasa-
531 162, Visakhapatnam District, Phone: 08933-225083/84/87



Anil Neerukonda Institute of Technology & Sciences (Autonomous)

(Affiliated to AU, Approved by AICTE & Accredited by NBA & NAAC with 'A' Grade)

Sangivalasa-531 162, Bheemunipatnam Mandal, Visakhapatnam District

Phone: 08933-225083/84/87

Fax: 226395

Website: www.anits.edu.in

email: principal@anits.edu.in

Vision of the Institute

ANITS envisions to emerge as a world-class technical institution whose products represent a good blend of technological excellence and the best of human values.

Mission of the Institute

To train young men and women into competent and confident engineers with excellent communication skills, to face the challenges of future technology changes, by imparting holistic technical education using the best of infrastructure, outstanding technical and teaching expertise and an exemplary work culture, besides molding them into good citizens



Anil Neerukonda Institute of Technology & Sciences (Autonomous)

(Affiliated to AU, Approved by AICTE & Accredited by NBA & NAAC with 'A' Grade)

Sangivalasa-531 162, Bheemunipatnam Mandal, Visakhapatnam District

Phone: 08933-225083/84/87

Fax: 226395

Website: www.anits.edu.in

email: principal@anits.edu.in

Vision of the Department

To become a centre of excellence in Education, research and produce high quality engineers in the field of Electronics and Communication Engineering to face the challenges of future technological changes.

Mission of the Department

To achieve vision department will

Transform students into valuable resources for industry and society by imparting contemporary technical education.

Develop interpersonal skills and leadership qualities among students by creating an ambience of academic integrity to participate in various professional activities

Create a suitable academic environment to promote research attitude among students.



Program Educational Objectives (PEOs):

PEO1 : Graduates excel in their career in the domains of Electronics, Communication and Information Technology.

PEO2 : Graduates will practice professional ethics and excel in professional career through interpersonal skills and leadership qualities.

PEO3 : Graduates demonstrate passion for competence in higher education, research and participate in various professional activities.

Program Outcomes (POs):

Engineering Graduates will be able to:

1. **Engineering knowledge:** Apply the knowledge of mathematics, science, engineering fundamentals, and an engineering specialization to the solution of complex engineering problems.
2. **Problem analysis:** Identify, formulate, review research literature, and analyze complex engineering problems reaching substantiated conclusions using first principles of mathematics, natural sciences, and engineering sciences.
3. **Design/development of solutions:** Design solutions for complex engineering problems and design system components or processes that meet the specified needs with appropriate consideration for the public health and safety, and the cultural, societal, and environmental considerations.
4. **Conduct investigations of complex problems:** Use research-based knowledge and research methods including design of experiments, analysis and interpretation of data, and synthesis of the information to provide valid conclusions.
5. **Modern tool usage:** Create, select, and apply appropriate techniques, resources, and modern engineering and IT tools including prediction and modeling to complex engineering activities with an understanding of the limitations.
6. **The engineer and society:** Apply reasoning informed by the contextual knowledge to assess societal, health, safety, legal and cultural issues and the consequent responsibilities relevant to the professional engineering practice.
7. **Environment and sustainability:** Understand the impact of the professional engineering solutions in societal and environmental contexts, and demonstrate the knowledge of, and need for sustainable development.
8. **Ethics:** Apply ethical principles and commit to professional ethics and responsibilities and norms of the engineering practice.
9. **Individual and team work:** Function effectively as an individual, and as a member or leader in diverse teams, and in multidisciplinary settings.
10. **Communication:** Communicate effectively on complex engineering activities with the engineering community and with society at large, such as, being able to comprehend and write effective reports and design documentation, make effective presentations, and give and receive clear instructions.
11. **Project management and finance:** Demonstrate knowledge and understanding of the engineering and management principles and apply these to one's own work, as a member and leader in a team, to manage projects and in multidisciplinary environments.
12. **Life-long learning:** Recognize the need for, and have the preparation and ability to engage in independent and life-long learning in the broadest context of technological change.

Program Specific Outcomes (PSOs):

PSO1 : Implement Signal & Image Processing techniques using modern tools.

PSO2 : Design and analyze Communication systems using emerging techniques.

PSO3 : Solve real time problems with expertise in Embedded Systems.

Microwave Engineering Laboratory	
ECE 424	Credits : 2
Instruction : 3 periods/Week	Sessional Marks : 50
End Exam : 3 Hours	End Exam Marks: 50

Course outcomes

At the end of the course, students will be able to

C01: Analyze the characteristics of microwave tubes.

C02: Measure the Frequency, Wavelength, VSWR and impedance of a microwave signal and load.

C03: Analyze the radiation pattern characteristics of horn antenna and yagi-uda antenna

C04: Determine the performance parameters of microwave junctions, directional coupler.

C05: Design a microstrip patch antenna with given specification using simulation tools.

CO-PO-PSO Mapping

	Po1	Po2	Po3	Po4	Po5	Po6	Po7	Po8	Po9	Po10	Po11	Po12	PSO1	PSO2	PSO3
C01	1	3	-	3	-	-	-	1	1	1	-	-	-	3	-
C02	1	3	-	3	-	-	-	1	1	1	-	-	-	3	-
C03	1	3	-	3	-	-	-	1	1	1	-	-	-	3	-
C04	1	3	-	3	-	-	-	1	1	1	-	-	-	3	-
C05	1	3	-	3	3	1	-	1	1	1	-	-	-	3	-



MICROWAVE ENGINEERING LABORATORY

INDEX

MICROWAVE EXPERIMENTS

Sl.No	NAME OF THE EXPERIMENT	
MICROWAVE EXPERIMENTS		
1.	Study of Microwave Components and Instruments	1
2.	Study of the Characteristics of Reflex Klystron Tube	2
3.	Frequency and Wave Length Measurement of a Signal	7
4.	Determination of VSWR of a Given Load	10
5.	Unknown Impedance Measurement using Smith Chart	14
6.	Study of V-I Characteristics of Gunn Diode	17
7.	Determination of Polar Plot of Horn Antenna	20
8.	Determination of Parameters of Directional Coupler	24
ANTENNAS EXPERIMENTS		
9.	Study of Antenna Trainer Kit	27
10.	Radiation Pattern of Yagi-Uda 3 Element Folded Dipole Antenna	30
11.	Radiation Pattern of Yagi-Uda 5 Element Folded Dipole Antenna	33
12.	Radiation Pattern Of $\lambda/2$ Phased Array Antenna	36
DESIGN EXPERIMENTS		
13.	Magic – Tee as Mixer	39
14.	Circulator as a Mixer	40
15.	Wave Guide Parameters Measurement	42
16.	Design of Rectangular Microstrip Patch Antenna with Coaxial Probe	43
17.	Design of Rectangular Microstrip Patch Antenna using Stripline Feed	48
18.	Design of Rectangular MicroStrip Patch Antenna with U-Shaped Slot Fed with strip line	53
19.	Design of Microstrip Triangular Patch Antenna Using Co-Axial Feed	57



**Scheme of Evaluation
(MICROWAVE ENGINEERING LABORATORY)**

Total marks for each student to evaluate in lab:

100

Out of 100 marks:

- 1. External Evaluation: 50 marks**
- 2. Internal Evaluation: 50 marks**
 - a. Internal Lab exam: 25 marks**
 - b. Continuous Evaluation : 25 marks**

Distribution of Continuous evaluation marks:

a)Viva on every lab session	:5M
b)Observation with final results	: 5M
c)Record	:10M
d)Attendance	:5M

Distribution of Record Marks(20M)(Later on, these marks would be scaled to 10M):

a)Aim	:1M
b)Apparatus	:2M
c)Circuit Diagram	:2M
d)Procedure	:2M
e)Theory	:4M
f)Observations Table	:4M
g)Calculations	:2M
h)Graph	:2M
i)Result/Conclusion	:1M

Internal / External Exam Marks division:

Internal Exam

Write up	:10M
Execution	:5M
Graphs & Result	:5M
Viva	:5M

External Exam

Write up	:20M
Execution	:10M
Graphs & Result	:10M
Viva	:10M

Write-Up Marks division(10M for internal lab exam & for external lab exam, every point below is allotted double the marks)

Aim	:1M
Apparatus	:1M
Circuit diagram	:4M
Procedure	:2M
Model Graph	:1M
Observation Table	:1M



Rubrics

MICROWAVE ENGINEERING LABORATORY

S.No	Competency	Performance Indicator
1.	Demonstrate an ability to conduct experiments consistent with their level of knowledge and understanding.	Laboratory preparation (verification of Lab observation)
		Stating clearly the aim of the experiment, its scope and importance for purpose of doing experiment.(Based on viva)
		Experimental procedures (Based on contents in Lab observation)
2.	Demonstrate an ability to design experiments to get the desired output.	Ability to build the circuit diagram and use meters/ instruments to record the measured data according to the range selected.(Based on physical observation)
		Finding the appropriate values of the components to meet the specifications.
3.	Demonstrate an ability to analyze the data and reach valid conclusions.	Analyze data for trends and correlations, stating possible errors and limitations in choosing the component values.
		Tabulate data (tabular form or in graphical form) from the results so as to facilitate analysis and explanations of the data, and draw conclusions.(Based on results)
		Ability to gather materials and writing in lab record (Based on lab record)

S.No	Performance Indicator	Excellent (A) 100%	Good(B) 80%	Need improvement (C) 60%	Fail (D) <40%
1.	Laboratory preparation & ability to construct the circuit diagram on a bread board and use meters/ instruments to record the measured data according to the range selected (Based on physical observation) (5M)	Read and understand the lab manual before coming to lab. Observations are completed with necessary theoretical calculations including the use of units and significant figures & Obtain the correct values of the components after calculations. Follow the given experimental procedures, to obtain the desired output.	Observations are completed with necessary theoretical Calculations but Without proper understanding & Obtain the correct values for only few components after calculations. Follow the given experimental procedures, but obtained results with some errors.	Observations are incomplete & Obtain the incorrect values for components. Lacks the appropriate knowledge of the lab procedures. Has no idea what to do	No effort exhibited
2.	Stating clearly the aim of the experiment, its scope and importance for purpose of doing experiment & Oral Presentation (Based on viva)(5M)	Clearly describes the purpose of doing experiment and its scope. Responds confidently, and precisely in giving answers to questions correctly	Clearly describes the purpose of doing experiment. Responds in giving answers to questions but some answers are wrong.	Some idea of doing experiment but not very clear & responds in giving answers to questions but all answers are wrong.	No effort exhibited
3.	Presentation of record & Conclusions of the lab experiment performed. (Based on Lab record)(10M)	Well-organized, interesting, confident presentation of record & able to correlate the theoretical concepts with the concerned lab results with appropriate reasons.	Presentation of record acceptable	Presentation of record lacks clarity and organized	No effort exhibited



Department of Electronics and Communication Engineering have a microwave laboratory which was established in the year 2004. It is meant for experiments at the instructional level for 4th year B.Tech students. The laboratory is equipped with microwave benches of X-band, which includes Klystron Tubes, GUNN Diodes, Klystron power supplies, Directional Couplers, VSWR meters and simulation software like HFSS and IE3D that provides students the necessary support for training them in the area of Antenna Design and Microwave Engineering.



DEPARTMENT OF ELECTRONICS AND COMMUNICATION ENGINEERING
Anil Neerukonda Institute of Technology & Sciences (Autonomous)
Sangivalasa-531 162, Bheemunipatnam Mandal, Visakhapatnam District

LIST OF MAJOR EQUIPMENT IN MICROWAVE ENGINEERING LABORATORY

SL.NO	NAME OF THE EQUIPMENT	MAKE	QUANTITY
1.	SX-9000 MICRO WAVE BENCH WITH KLYSTRON POWER SUPPLY	SICO	07
2.	SX 9001 MICRO BENCH WITH GUNN POWER SUPPLY.	SICO	02
3.	OFT OPTICAL FIBER AND DIGITAL COMMUNICATION TRAINER KIT	BENCHMARK	05
4.	HORN ANTENNA RADIATION PATTERN MICROWAVE BENCH	SICO	01
6.	ANTENNA TRAINER SYSTEM WITH MOTORIZED ROTATING UNIT PLOTTING SOFTWARE WITH 22 ANTENNAS	SCIENTECH	01
7.	TRANSMISSION LINE TRAINER	SCIENTECH	02
8.	HFSS SOFTWARE	ANSYS	01
9.	PC SYSTEM	HP	01

TOTAL EXPENDITURE OF THE LABORATORY: Rs. 19,42,876.00/-



Microwave Engineering and Antenna Laboratory

Do's

1. Be punctual and regular to the laboratory.
2. Maintain discipline and obey instructions all the time.
3. Inspect all equipment for damage prior to use—do not use damaged equipment.
4. Check the connections properly before Turning ON the circuit.
5. Turn OFF the circuit immediately if you see any component heating.
6. Dismount all the components before returning the kit.
7. Any failure / break-down of equipment must be reported to the faculty
8. Know emergency procedures.

Don'ts

1. Don't touch live electric wires.
2. Don't TURN ON the circuit unless it is completed.
3. Avoid making loose connections.
4. Don't leave the lab without permission.
5. Do not handle any equipment before reading the instructions/Instruction manuals
6. Do not use the prohibited items like personal audio or video equipment in the laboratory
7. Never block access to EXITs or emergency equipment.
8. Never leave experiments while in progress.

1. STUDY OF MICROWAVE COMPONENTS AND INSTRUMENTS

AIM

To become familiar with microwave components and instruments available in the laboratory

INSTRUMENTS/EQUIPMENTS

- (1) Reflex klystron power supply
- (2) Gunn power supply,
- (3) VSWR meter
- (4) Slotted Line section
- (5) Frequency Meter
- (6) RF Generator

OBJECTIVES

- Note relevant Technical specifications of the instruments
- Study position and functions of the front panel controls of the equipment
- Know basic principle of operation and functional block diagram of the instrument.
- Limitations and handling of the equipment
- Various options provided on the front panel.
- Know initial settings of controls of the equipment before switching on the supply.
- Precautions to be taken while carrying out the measurements

COMPONENTS/DEVICES

Attenuator, Circulator, Isolator, wave-guide twist, bend, Magic tee, Directional Coupler, Matched termination, PIN Modulator, Crystal Detector, Reflex Klystron tube, Gunn diode, different types of antennas available.

OBSERVATIONS

- Identify the components/devices
- Study basic principle of operation of devices and components
- Know typical application of each component.
- Identify the E field and H field mode patterns of the devices.

PRECAUTIONS

- Beam voltage should not exceed 250V
- Reflected voltage should not exceed 270V
- Fan should be operated to reduce the heat for reflex klystron
- Every 20 minutes switch of the supply and set the initial conditions.
- Carefully follow the specifications of the device and equipment.

RESULT:

Studied various microwave components and devices.

2. STUDY OF CHARACTERISTICS OF REFLEX KLYSTRON TUBE

AIM

To study the Characteristics of the reflex klystron tube and to determine its electronic tuning range.

EQUIPMENT

- (1) Klystron power supply SKPS-610
- (2) Klystron Tube 2k-25 with klystron Mount XM-251
- (3) Isolator XI- 621
- (4) Frequency Meter XF-710
- (5) Variable Attenuator XA-520
- (6) Detector Mount XD-451
- (7) Wave Guide Stand XU-535
- (8) VSWR Meter SW-215
- (9) Oscilloscope
- (10) BNC Cable

BLOCK DIAGRAM

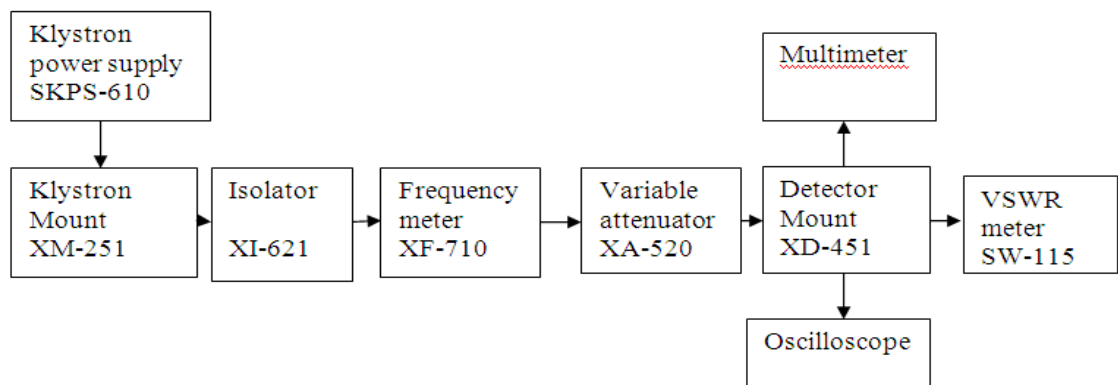

Fig: SET UP FOR REFLEX KLYSTRON TUBE

THEORY

The Reflex Klystron makes the use of velocity modulation to transform a continuous Electron beam into microwave power. Electrons emitted from the cathode are accelerated & passed through the positive resonator towards negative reflector, which retards and, finally, reflects the Electrons and the electrons turn back through the resonator. Suppose an RF-field exists between the Resonators; the electrons travelling forward will be accelerated or retarded, as the voltage at the Resonator changes in amplitude. The accelerated electrons leave the resonator at an increased velocity and the retarded electrons leave at the reduced velocity.

The electrons leaving the resonator will need different time to return due to change in velocities. As a result, returning electrons group together in BUNCHES pass through the grid at such a time that the electrons are slowed down by the voltage then energy will be delivered to the resonator; and Klystron will oscillate. Fig shows the relation ship between out put Power, frequency and reflector voltage. The dimensions of resonant cavity primarily determine the frequency. Hence, by changing the volume of resonator, mechanical turning of klystron is possible. Also a small frequency change can be obtained by adjusting the reflector voltage. This is called Electronic Tuning.

PROCEDURE

A. Carrier wave operation

- Connect the components and equipments as shown in the fig
- Set the variable Attenuator at the minimum at position.
- Set the mod switch of Klystron Power supply at CW position, beam voltage control knob to fully anticlock wise and reflector voltage control knob to fully clockwise and the Meter switch to OFF position.
- Rotate the knob of frequency meter at one side fully.
- Connect the D.C microampere meter with Detector.
- Switch ON the klystron power supply, VSWR Meter and cooling fan for the klystron tube.
- Switch on the beam voltage knob and rotate it clockwise slowly up to 250V meter reading and observe beam current should not increase more than 30mA.
- Change the reflector voltage slowly and verify the current meter the voltage for reading maximum deflection in the meter.
- Turn the plunger of klystron Mount for the maximum output.
- Rotate the knob of frequency meter slowly and stop at that position, where the lowest out put current on multi meter. Read directly the frequency meter reading between two horizontal lines and vertical marker.
- Change the reflector voltage and read the corresponding current and frequency for each reflector voltage.

B. Square wave operation

- Connect the equipments and components as show in fig
- Set micrometer of variable attenuator around some position.
- Set the range switch of VSWR meter at 40db position. Input selector switch to crystal impedance position, meter switch to normal position.
- Set mod selector switch to AM –MOD position. Beam voltage control knob to fully anticlockwise position.
- Switch ON the klystron power supply, VSWR meter and cooling fan.
- Switch ON the beam voltage switch and rotate the beam voltage knob clockwise up to 300V deflection in meter.
- Keep the AM-MOD amplitude knob and AM-FRE knob at the mid –position.
- Rotate the reflector voltage knob to get deflection in VSWR meter.
- Rotate the AM-MOD amplitude knob to get the maximum output in VSWR meter

- Maximize the deflection with frequency knob to get the maximum output in VSWR meter.
- If necessary, change the range switch of VSWR meter 30dbto50db if the deflection in VSWR meter is out of scale or less than normal scale respectively. Further variable attenuator is used for setting up the particular position by reducing the output.
- Determine the oscillator frequency as described in the earlier setup.

C. Mode study on oscilloscope

- Setup the components and equipments as shown in fig.
- Keep the position of variable attenuator at min. attenuation position.
- Set mode selector switch to FM- MOD position, FM amplitude and FM frequency knob at mid position keep the beam voltage knob fully anti-clockwise and beam switch to OFF position.
- Keep the time /division scale of oscilloscope around 100HZ frequency measurement and volt/div. to lower scale.
- Switch ON the klystron power supply and oscilloscope.
- Switch ON beam voltage switch and set beam voltage to 250V by beam voltage control knob.
- Keep amplitude knob of FM modulator to maximum position and rotate the reflector voltage knob anticlockwise to get modes as shown in fig. on the oscilloscope.
- Klystron tube can be seen on oscilloscope by changing the reflector voltage and amplitude of FM modulation, any mode of klystron tube can be seen on oscilloscope

OBSERVATIONS

Beam Voltage $V_B =$
 Beam Current $I_B =$
 Resistance $R = 1\Omega$

Tabular Form

Voltage(V_R)	Current(I)	Power $=I^2 R$

PRECAUTIONS

- Beam voltage should not exceed 250V
- Reflected voltage should not exceed 270V
- Fan should be operated to reduce the heat for reflex klystron
- Every 20 minutes switch of the supply and set the initial conditions.
- Carefully follow the specifications of the devices and equipment.

MODEL GRAPHS:

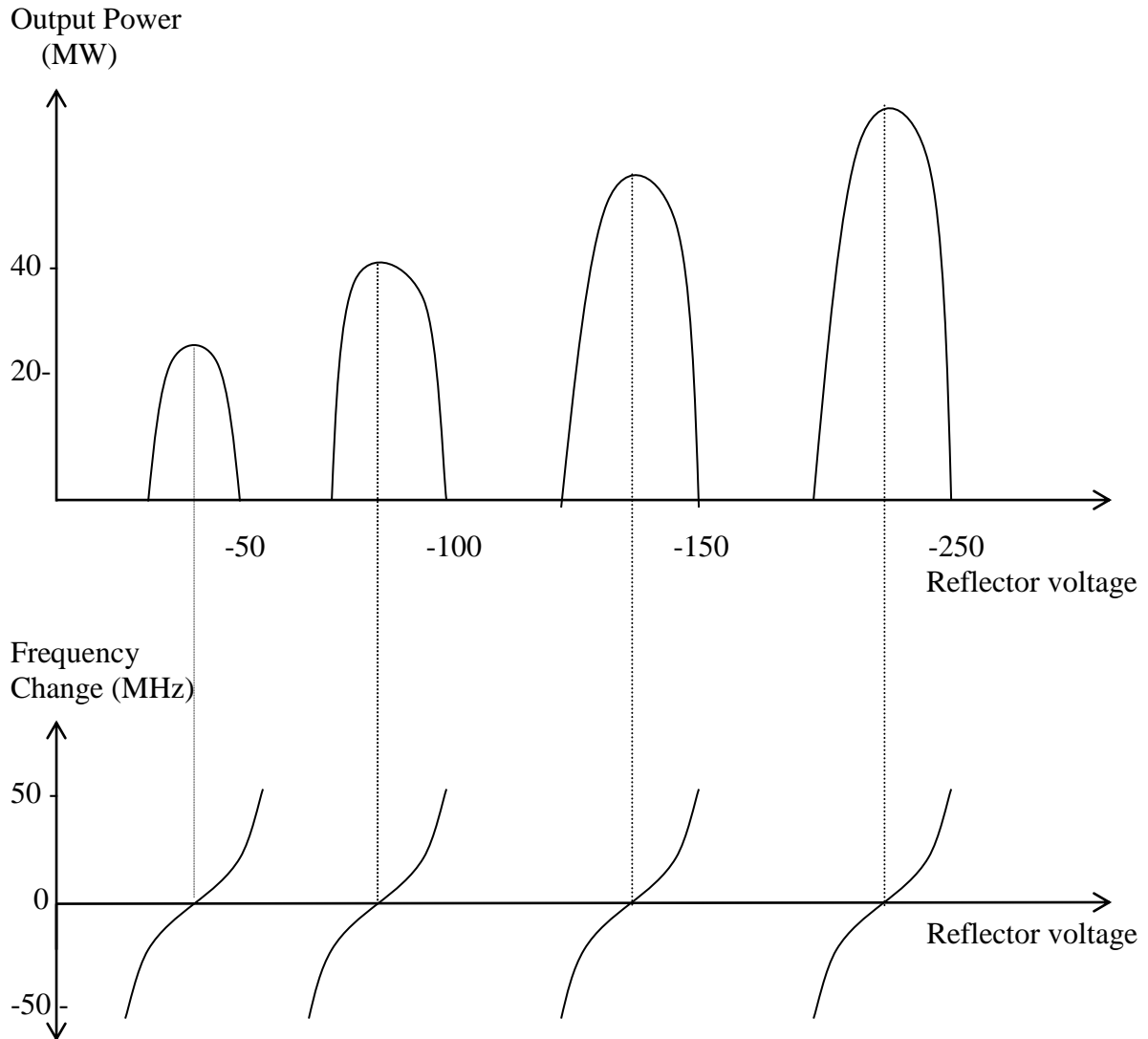

RESULT:

The characteristics of Klystron tube are observed on oscilloscope

VIVA QUESTION

1. What element of the reflex klystron replaces the output cavity of a normal klystron?
2. When the repeller potential is constant, what property of the electron determines how long it will remain in the drift space of the reflex klystron?
3. The constant-speed electrons of an electron bunch in a reflex klystron must remain in the repeller field for what minimum time?
4. If the constant-speed electrons in a reflex klystron remain in the repeller field for $1\frac{3}{4}$ cycles, what is the mode of operation?
5. Debunching of the electron bunches in the higher modes of a reflex klystron has what effect on output power?
6. What limits the tuning range around the center frequency of a reflex klystron in a particular mode of operation?

3. FREQUENCY AND WAVELENGTH MEASUREMENT OF A SIGNAL

AIM

To determine the frequency and wave length of a signal in a rectangular wave guide working in TE₁₀ Mode

EQUIPMENT

- (1) Klystron power supply SKPS-610
- (2) Klystron Tube 2k-25 with klystron Mount XM-251
- (3) Isolator XI-621
- (4) Frequency Meter XF-710
- (5) Variable Attenuator XA-520
- (6) Slotted section XS-651
- (7) Wave Guide Stand XU-535
- (8) VSWR Meter SW-215
- (9) Oscilloscope
- (10) Matched termination XL-400
- (11) Movable short XT-481
- (12) BNC Cable

BLOCK DIAGRAM

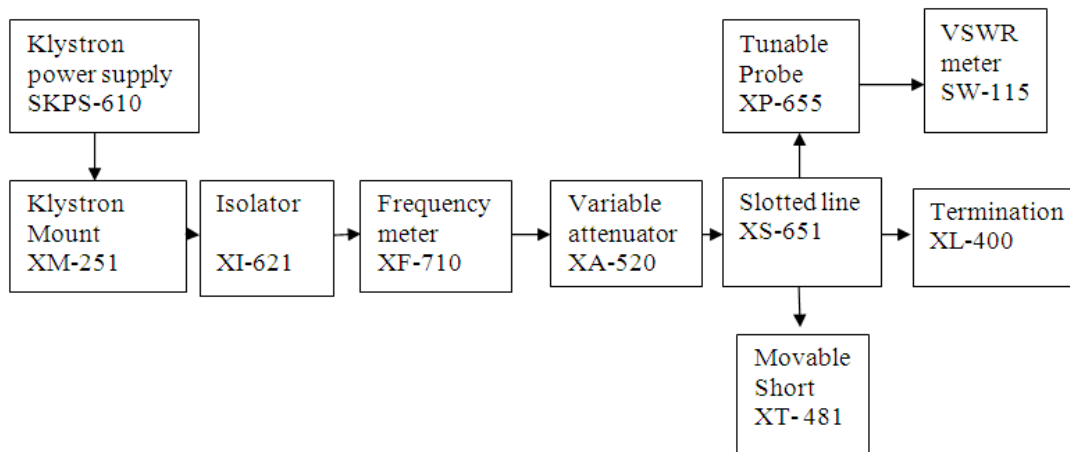

Fig : SET UP FOR FREQUENCY AND WAVELENGTH MEASUREMENT

THEORY

For dominant TE₁₀ mode rectangular wave-guide λ_0 , λ_g and λ_c are related as below

$$\frac{1}{\lambda_0^2} = \frac{1}{\lambda_g^2} + \frac{1}{\lambda_c^2}$$

where λ_0 is free space wavelength

$$\lambda_g \text{ (guide wavelength)} = 2(d_1 \sim d_2)$$

$$\lambda_c \text{ (cutoff wavelength)}$$

For TE₁₀ mode $\lambda_c = 2a$ where 'a' is broad dimension of wave guide

PROCEDURE

- Set up the components and equipment as shown in fig. above.
- Set the variable Attenuator at the minimum attenuation position.
- Keep the control knobs of VSWR Meter as bellow:
 - Range - 50db
 - Input switch - crystal low impedance
 - Meter switch - Normal position
 - Gain - Mid position
- Keep the control knobs of klystron power supply as bellow
 - Beam Voltage - OFF
 - Mod switch - AM
 - Beam voltage knob - fully anticlockwise
 - Reflector Voltage - fully clockwise
 - AM amplitude knob - Around fully clockwise
 - AM Frequency knob - Around mid
- Switch ON the klystron power supply, VSWR meter and cooling fan.
- Switch ON the beam voltage switch and rotate the beam voltage knob clockwise up to 200v deflection in meter.
- Keep the AM-MOD amplitude knob and AM-FREQ knob at the mid –position.
- Rotate the reflector voltage knob to get deflection in VSWR meter.
- Rotate the AM-MOD amplitude knob to get the maximum output in VSWR meter
- Maximize the deflection with frequency knob to get the maximum output in VSWR meter
- Tune the probe for maximum deflection in VSWR meter
- Tune the frequency meter knob to get a 'dip' on the VSWR meter scale and note down the frequency directly from the frequency meter
- Replace the termination with movable short and detune the frequency meter
- By moving the probe along the slotted line vary the deflection on VSWR meter.
- Move the probe to a minimum deflection position. Note and record the probe position
- Move the probe to next minimum position and record the probe position again
- Calculate guide wavelength as twice the distance between two successive minimum positions obtained as above
- Measure the wave guide inner broad dimension 'a' which will be around 22.86 mm for X-band
- Calculate frequency by following equation

$$f = \frac{C}{\lambda_0}$$

Where, velocity of light, $C = 3 \times 10^8$ meter/sec

OBSERVATIONS

1. Frequency from Frequency meter $f^1 =$ _____
2. Cut off Wavelength $\lambda_c = 2a =$ _____ ($a=22.86\text{mm}$ broad dimension of wave guide)
3. Guided Wavelength $\lambda_g = 2 (d_1 \sim d_2)$ $d_1 =$ _____ $d_2 =$ _____
(d_1 & d_2 found from movable short)
4. Free space Wavelength $\frac{1}{\lambda_0^2} = \frac{1}{\lambda_g^2} + \frac{1}{\lambda_c^2}$
5. Practical Frequency $f = \frac{C}{\lambda_0}$
6. $f^1 \sim f$

PRECAUTIONS

- Beam voltage should not exceed 250V
- Reflected voltage should not exceed 270V
- Fan should be operated to reduce the heat for reflex klystron
- Every 20 minutes switch of the supply and set the initial conditions.
- Carefully follow the specifications of the devices and equipment.

RESULT: The frequency and wave length in a rectangular working in TE_{10} mode are measured.

Frequency (f) = _____

Wavelength (λ_0) = _____

VIVA QUESTIONS

1. How are wavelength measured?
2. How do you measure wavelength in a compression wave?
3. What is the units of measure for wavelength?
4. What is frequency and how is it measured?
5. What is the frequency of waves measure in?

4. DETERMINATION OF VSWR OF A GIVEN LOAD

AIM

To determine the standing wave ratio and reflection coefficient

EQUIPMENT

- (1) Klystron power supply SKPS-610
- (2) Klystron Tube 2k-25 with klystron Mount XM-251
- (3) Isolator XF- 621
- (4) Frequency Meter XF-710
- (5) Variable Attenuator XA-520
- (6) Slotted line XS-565
- (7) Tunable probe XP-655
- (8) Wave Guide Stand XU-535
- (9) VSWR Meter SW-215
- (10) SS Tuner XT-441
- (11) Movable short/Termination XL-400

BLOCK DIAGRAM

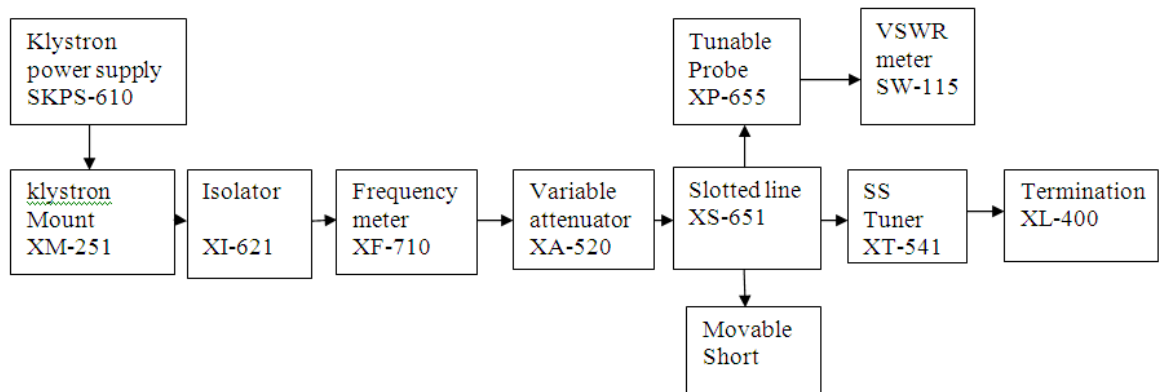

SET UP FOR VSWR MEASUREMENT

THEORY

The electromagnetic field at any point of transmission line may be considered as the sum of two traveling waves the incident wave, which propagates from the source to the load and the reflected wave, which propagates towards the generator. The reflected wave is set up by reflection of incident wave from a discontinuity in the line or from the load impedance. The superposition of two traveling waves gives rise to a standing wave along the line. The maximum field strength is found where the waves are in phase and minimum where the two waves add in opposite phase. The distance between two successive minimum (maximum) is half the guide wavelength on the line. The ratio of electric field strength of reflected and instant wave is called reflection coefficient.

The voltage standing wave ratio (VSWR) is defined as ratio between maximum and minimum field strength along the line

Hence VSWR denoted by S is as follows

$$S = \frac{E_{MAX}}{E_{MIN}} = \frac{|E_i| + |E_r|}{|E_i| - |E_r|}$$

Reflection coefficient, ρ is

$$\rho = \frac{E_r}{E_i} = \frac{Z_L - Z_0}{Z_L + Z_0}$$

where Z_L is the load impedance and Z_0 is characteristic impedance

The above equation gives following equation

Reflection Coefficient

$$\rho = \frac{S - 1}{S + 1}$$

PROCEDURE

- Set up the components and equipment as shown in fig .
- Set the variable Attenuator at the minimum at position.
- Keep the control knobs of VSWR Meter as bellow:
 - Range - 50db
 - Input switch - crystal low impedance
 - Meter switch - Normal position
 - Gain - Mid position
- Keep the control knobs of klystron power supply as bellow
 - Beam Voltage - OFF
 - Mod switch - AM
 - Beam voltage knob - fully anticlockwise
 - Reflector Voltage - fully clockwise
 - AM amplitude knob - around fully clockwise
 - AM Frequency knob - Around mid
- Switch ON the klystron power supply, VSWR meter and cooling fan.
- Switch ON the beam voltage switch and rotate the beam voltage knob clockwise up to 200v deflection in meter.
- Rotate the reflector voltage knob to get deflection in VSWR meter.
- Rotate the AM-MOD amplitude knob to get the maximum output in VSWR meter
- Maximize the deflection with frequency knob to get the maximum output in VSWR meter
- Tune the probe for maximum deflection in VSWR meter
- By moving the probe along the slotted line the deflection will change.

A. Measurement of low and medium VSWR

- Move the probe along the slotted line to get maximum deflection in VSWR meter.
- Adjust the VSWR meter gain control knob or variable attenuator until the meter indicates 1.0 on normal VSWR scale.
- Keep all the control knobs as same, move the probe to next minimum position. Read the VSWR on scale.
- Repeat the above step for changing of SS tuner probe depth and record the corresponding SWR.
- If the VSWR is between 3.2 and 10 change the range db switch to next higher position and read the VSWR on second VSWR scale of 3 to 10.

B. Measurement of High VSWR (Double Minimum method)

- Set the depth of SS tuner slightly more for maximum VSWR.
- Move the probe along with slotted line until a minimum is indicated.
- Adjust the VSWR meter gain control knob and variable attenuator to obtain a reading of 3 db in the normal db scale (0 to 10 db) of VSWR meter.
- Move the probe to the left on slotted line until full-scale deflection is obtained on 0 to 10dB scale. Note and record the probe position on slotted line let it be d_1 .
- Repeat the step 3 and then move the probe right along the slotted line until full-scale deflection is obtained on 0-10dB normal db scale. Let it be d_2 .
- Replace the SS tuner and termination by movable short.
- Measure the distance between two successive minimum positions of the probe. Twice this distance is guide wavelength λ_G .
- Compute SWR from the following equation:

$$SWR = \frac{\lambda_g}{\pi(d_1 \sim d_2)}$$

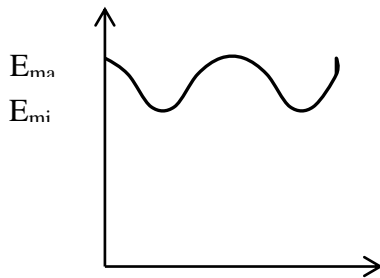

STANDING WAVE

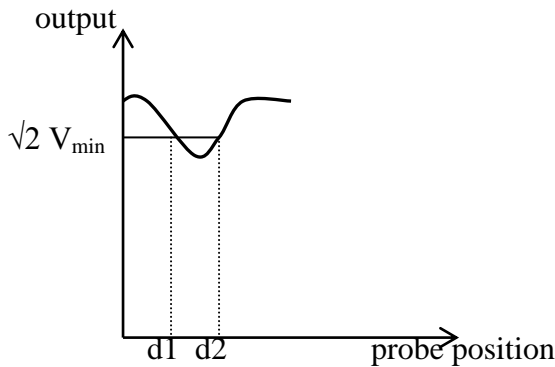

PRECAUTIONS

- Beam voltage should not exceed 250V
- Reflected voltage should not exceed 270V
- Fan should be operated to reduce the heat for reflex klystron
- Every 20 minutes switch OFF the supply and set the initial conditions.
- Carefully follow the specifications of the devices and equipment.

RESULT : The Low, Medium and High VSWR of the given set up is measured

Low VSWR = _____
 Medium VSWR = _____
 High VSWR = _____

VIVA QUESTIONS

1. Does VSWR vary with line length?
2. Can the magnitude of the reflection coefficient (ρ) be greater than 1?
3. Can VSWR be negative?
4. Is there a the minimum length of transmission line required on either side of the VSWR meter for valid readings?
5. Is the characteristic impedance of the sampler line section important?
6. What is an acceptable VSWR?

5. UNKNOWN IMPEDANCE MEASUREMENT USING SMITH CHART

AIM

To measure the unknown impedance by using smith chart.

EQUIPMENT

- (1) Klystron power supply –SKPS-610
- (2) Klystron Tube2k-25 with klystron Mount-XM251
- (3) Isolator XF- 621
- (4) Frequency MeterXF-710
- (5) Variable Attenuator XA-520
- (6) Slotted line XS 565
- (7) Tunable probeXP655
- (8) Wave Guide StandXU-535
- (9) VSWR MeterSW-215
- (10) SS Tuner XT441
- (11) Movable short/Termination XL-400

BLOCK DIAGRAM

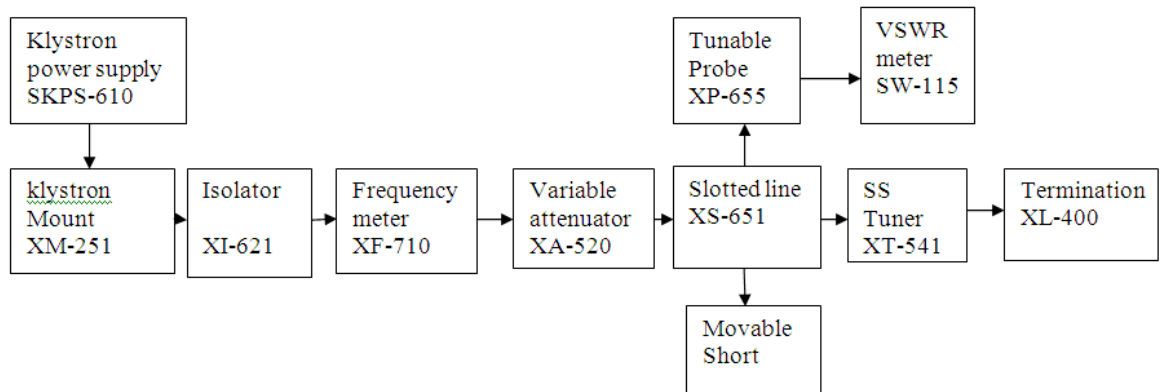

Fig: SET UP FOR UNKNOWN IMPEDANCE MEASUREMENT

THEORY

The impedance at any point on a transmission line can be written in the form $R+jX$
For comparison SWR can be calculated as

$$S = (1 + |R|) / (1 - |R|)$$

Where Reflection co-efficient $R = (Z - Z_0) / (Z + Z_0)$

Z_0 is the Characteristic impedance of wave-guide at operating frequency & Z is the load impedance. The measurement is performed in the following way, the unknown device is connected to the slotted line and the position of one minimum is determined. The unknown device is replaced by movable short to the slotted line.

Two successive minima positions are noted. The twice of the difference between two minima positions will be the guide wavelength. One of the minimums is used as reference for impedance measurement. Find the difference of reference minima and minima position obtained from unknown load. Let it be 'd'. Take a smith chart, taking 1 as center, draw a circle of radius equal to S. Mark a point on circumference of smith chart towards load side at a distance equal to d/λ . Join the center with this point. Find the point where it cut the drawn circle. The co-ordinates of this point will show the normalized impedance of load.

PROCEDURE

- Set up the components and equipment as shown in fig.
- Set the variable Attenuator at the minimum at position.
- Keep the control knobs of VSWR Meter as bellow:

Range	- 50db
Input switch	- crystal low impedance
Meter switch	- Normal position
Gain	- Mid position
- Keep the control knobs of klystron power supply as bellow

Beam Voltage	- OFF
Mod switch	- AM
Beam voltage knob	- fully anticlockwise
Reflector Voltage	- fully clockwise
AM amplitude knob	- around fully clockwise
AM Frequency knob	- Around mid
- Switch ON the klystron power supply, VSWR meter and cooling fan.
- Switch ON the beam voltage switch and rotate the beam voltage knob clockwise up to 200v deflection in meter.
- Rotate the reflector voltage knob to get deflection in VSWR meter.
- Rotate the AM-MOD amplitude knob to get the maximum output in VSWR meter
- Maximize the deflection with frequency knob to get the maximum output in VSWR meter
- Tune the probe for maximum deflection in VSWR meter
- Tune the frequency meter knob to get a 'dip' on the VSWR meter scale and note down the frequency directly from the frequency meter
- Keep the depth of the S.S Tuner to around 3-4mm and lock it.
- Move the probe along the slotted line to get maxim deflection.
- Adjust VSWR meter gain control knob and variable attenuator until the meter indicates 1.0 on the normal db SWR scale.
- Move the probe to next minima position and note down the SWR 'S₀' on the scale.
- Also Note down the probe position, let it be d
- Replace the termination with movable short and detune the frequency meter
- By moving the probe along the slotted line. Vary the deflection on VSWR meter. Move the probe to a minimum deflection position. Note and record the probe position
- Move the probe to next minimum position and record the probe position again. Calculate guide wavelength as twice the distance
- Calculate $\frac{d}{\lambda_g}$

OBSERVATIONS

Frequency from Frequency meter $f^1 =$ _____

Low VSWR(S_0) = _____

First Minima $d =$ _____

$d_1 =$ _____

$d_2 =$ _____

Guided Wavelength $\lambda_g = 2 (d_1 \sim d_2) =$ _____

$d / \lambda_g =$ _____

From Graph:

Normalized Load Impedance $(Z_L)_N = R \pm jX$

Characteristic Impedance $Z_o = 377 * (b/a) * (\lambda_g / \lambda_o)$

$$f = \frac{C}{\lambda_o}$$

For TE₁₀, $b = 10.06\text{mm}$ (Narrow wall dimension of a rectangular waveguide)

$a = 22.86\text{mm}$ (Broad wall dimension of a rectangular waveguide)

$$Z_L = (Z_L)_N * Z_o$$

PRECAUTIONS

- Beam voltage should not exceed 250V
- Reflected voltage should not exceed 270V
- Fan should be operated to reduce the heat for reflex klystron
- Every 20 minutes switch of the supply and set the initial conditions.
- Carefully follow the specifications of the devices and equipment.

RESULT: The unknown impedance using smith chart is measured

Unknown Impedance = _____

VIVA QUESTIONS

1. What are the applications of the smith chart
2. What does SS mean in SS-tuner
3. What is the relation between the reflection coefficient and the load impedance
4. Name few scales on the radial axis of the smith chart
5. What type of load it represents if the load is in the positive half of the smith chart

6. STUDY OF V-I CHARACTERISTICS OF GUNN DIODE

AIM

To study the V-I Characteristics of given Gunn diode

EQUIPMENT

- (1) Gunn Power Supply
- (2) Gunn Oscillator XG-11
- (3) Isolator XI-621
- (4) Frequency Meter XF-710
- (5) Matched Termination XL-400

BLOCK DIAGRAM

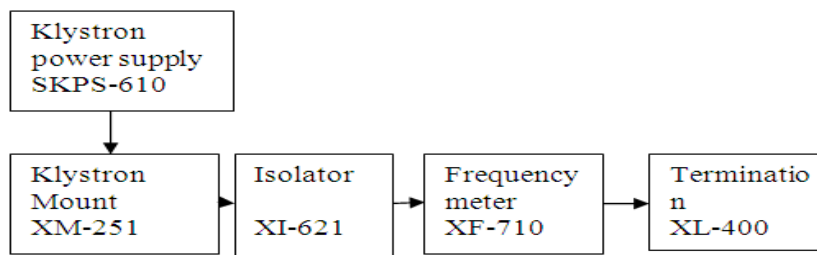

Fig: SET UP FOR THE STUDY OF V-I CHARACTERISTICS OF GUNN OSCILLATOR

PROCEDURE

- Set the components as shown in the fig.
- Keep the control knobs of Gunn power supply as bellow
 - Meter Switch - OFF
 - Gunn bias knob - Fully anticlockwise
 - Pin bias knob - Fully anticlockwise
 - Pin mode frequency - Any position
- Set the micrometer of Gunn oscillator for required frequency of operation
- Switch ON the Gunn power supply.
- Measure the Gunn diode current corresponding to the various Gunn bias voltages through the digital panel meter and meter switch. Do not exceed the bias voltage above 10 volts
- Plot the voltage and current reading on the graph as shown in fig.
- Measure the threshold voltage, which corresponds to maximum current.

READINGS

Frequency(GHz)	Micrometer Reading(mm)
12.4	5.65
12.2	6.15
12	6.65

11.8	6.86
11.6	7.50
11.4	7.75
11.2	8.44
11	9.14
10.8	9.50
10.6	10.07
10.4	10.79
10.2	11.48
10	12.26
9.8	13.10
9.6	14.11
9.4	15.17
9.2	16.29

OBSERVATIONS

Micrometer reading =

Frequency=

Voltage(V)	Current(mA)

PRECAUTIONS

- Gunn bias not exceed 10V
- Fan should be operated to reduce the heat for Gunn oscillator
- Every 20 minutes switch of the supply and set the initial conditions.
- Carefully follow the specifications of the devices and equipment.

MODEL GRAPH

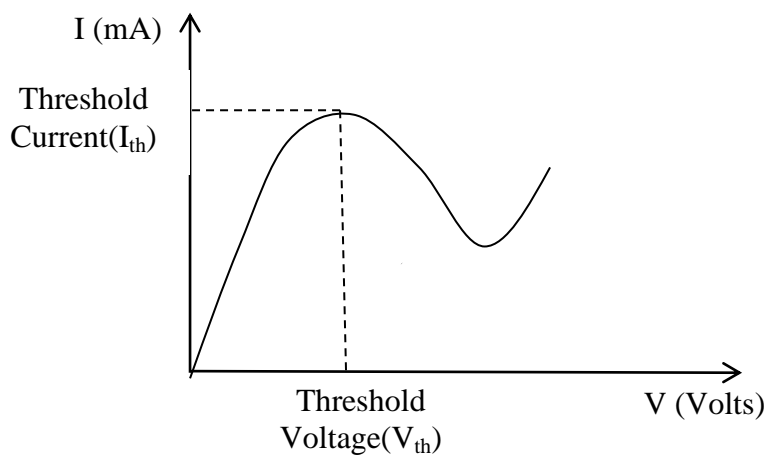

V-I CHARACTERISTICS OF GUNN OSCILLATOR

RESULT: Gunn Diode V-I Characteristics are observed.

VIVA QUESTIONS

1. Why Gunn diode and IMPATT diode are not common microwave devices?
2. Difference between Gunn diode and PIN diode?
3. What does diode mean ?
4. What are regions of operation in Gunn diode?
5. Explain different modes of operation in Gunn diode.

7. DETERMINATION OF HORN ANTENNA POLAR PLOT

AIM

To measure the polar pattern and the gain of a wave guide horn antenna.

EQUIPMENT

- (1) Gunn Power Supply GS-610
- (2) Gunn Oscillator XG-11
- (3) PIN Modulator XM-55
- (4) Isolator XI-621
- (5) Variable Attenuator XA-520
- (6) Detector Mount XD-451
- (7) VSWR Meter
- (8) Radiation Pattern XTB-105
- (9) Standard gain Horn XH-541
- (10) E-Plane bends XB771
- (11) Wave guide Stand XU-535
- (12) Frequency Meter XF-710
- (13) Cooling Fan CF-205

BLOCK DIAGRAM

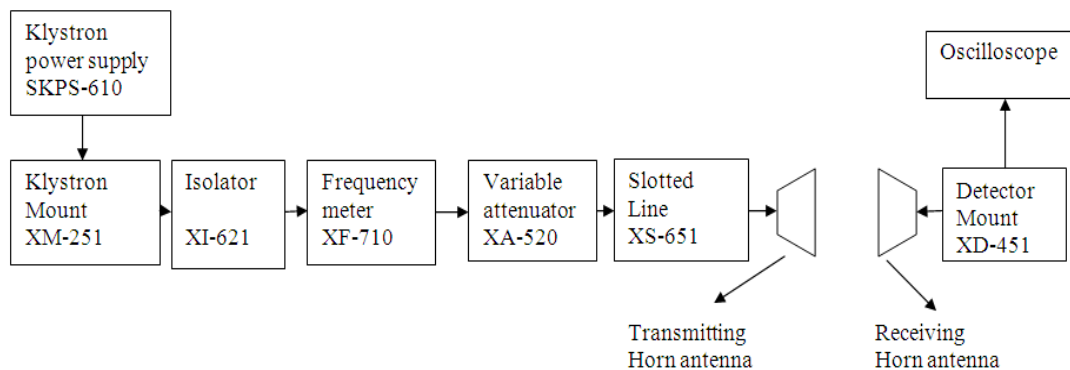

Fig: SET UP FOR HORN ANTENNA PATTERN MEASUREMENT

THEORY

If a transmission line, propagating energy is left open at one end. In case of rectangular wave-guide this antenna presents a mismatch of about 2 and it radiates in many directions. The match will improve if the open wave-guide is a horn shape. The radiation pattern of antenna is a plot of field strength of power intensity as a function of the aspect angle at a constant distance from the radiating antenna. An antenna pattern is of course three-dimensional but for practical reasons it is normally presented as two-dimensional pattern in one or several planes. An antenna pattern consists of several lobes the main lobe, side lobes, and back lobe. The major power is concentrated in the main lobe and it is required to keep the power in the side lobes and back lobe as low as possible. The power intensity at the maximum in

the main lobe compared to the power intensity achieved from an imaginary omni directional antenna (radiating equally in all directions) with the same power fed to the antenna is defined as gain of the antenna.

3dB beam width

- This is the angle between two points on a main lobe where the power intensity is half the maximum power intensity. The antenna pattern measurement is always done in far field region.
- For field pattern is achieved at a minimum distance of $2D^2/\lambda_0$ (for rectangular horn antenna) where D is size of the broad wall of horn aperture λ_0 is free space wavelength.
- It is also important to avoid reflection; antenna measurement is done at outdoor ranges or in anechoic chambers made of absorbing materials.
- Antenna measurements are mostly made with unknown antenna as receiver; therefore several methods are there to measure the gain of antenna one method is to compare the unknown antenna with standard gain antenna with known gain. Another method is to use two identical antennas. One as a transmitter and other as receiver and from following formula the gain can be calculated.

$$P_r = \frac{P_t G_1 G_2}{(4\pi S)^2}, \quad G = \frac{4\pi S}{\lambda_0} \sqrt{\frac{P_r}{P_t}}$$

where P_t is transmitted power P_r is received power G_1, G_2 is gain of the transmitting and Receiving antennas respectively, S is the radial distance between two antennas. and λ_0 is free space wavelength

- If both transmitting and receiving antenna are identical having gain G then

$$P_r = \frac{P_t \lambda_0 G^2}{(4\pi S)^2}$$

- In the above equation P_t, P_r, S and can be measured and gain can be computed. As from the above equation it is not necessary to know the absolute value of P_t and P_r only ratio is required, which, can be measured by VSWR meter

PROCEDURE

- Assemble the components and equipments as shown in figure
- The reading on thr rotary scale should indicate 0° when the horns are in line.
- To avoid disturbing reflections make sure that no conducting objects are closer to the propagation path.
- Set the variable attenuator at minimum attenuation position.
- Switch on the KPS, turn the beam switch to ON.
- Keep the beam voltage knob at minimum position.
- Keep the modulation switch of klystron in square wave.
- Set the attenuator for proper square wave of sufficient amplitude.
- Varying repeller voltage set the Klystron at its maximum mode.
- Vary the frequency meter in order to get dip in the output waveform.
- Calculate the distance between the transmitter and receiver horn antenna.
- Turn the receiving horn in steps of 5° from 0° to 360° and note down the corresponding the voltage levels from CRO.

- Plot the radiation pattern of the antenna on polar plot of the antenna on polar graph sheet. This gives H-Plane pattern of antenna.

OBSERVATIONS

Beam Voltage(V_B)= _____
 Beam Current(I_B)= _____
 Repeller Voltage(V_R)= _____
 Diameter (D)= _____ (broad wall of horn aperture)
 Dip Frequency(f_0) $\lambda_0=C/f_0$

Where C= Velocity of Light

Range®= $2D^2/\lambda_0$ = _____

PRECAUTIONS

- Beam voltage should not exceed 250V
- Reflected voltage should not exceed 270V
- Fan should be operated to reduce the heat for reflex klystron
- Every 20 minutes switch of the supply and set the initial conditions.
- Carefully follow the specifications of the devices and equipment.

TYPICAL ANTENNA PATTERN

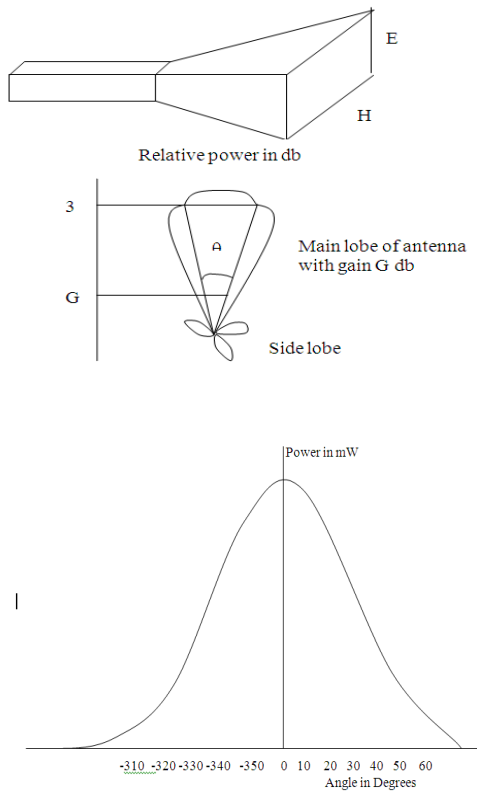

RESULT: The polar pattern and Beam width of wave guide horn antenna is measured

A QUESTIONS

1. What is horn?
2. In order to function properly, a horn antenna must be a certain minimum size .What is it?
3. Where are Horn antennas commonly used ?
4. Why we use horn, rather than a dipole antenna or any other type of antenna, at the focal point of the dish
5. Mention few application of Horn antenna
6. What is the use of the horn shaped structures at the end of the waveguide

8. DETERMINATION OF PARAMETERS OF DIRECTIONAL COUPLER

AIM

To study the function of a multihole directional coupler by measuring the following parameters

- a) The coupling factors b) the directivity of coupler.

EQUIPMENT

- (1) Klystron power supply –SKPS-610
- (2) Klystron Tube2k-25 with klystron Mount-XM251
- (3) Isolator XF- 621
- (4) Frequency MeterXF-710
- (5) Variable Attenuator XA-520
- (6) MHD Coupler
- (8) Wave Guide StandXU-535
- (9) VSWR MeterSW-215
- (10) Detector mount
- (11) Movable short/Termination XL-400

BLOCK DIAGRAM

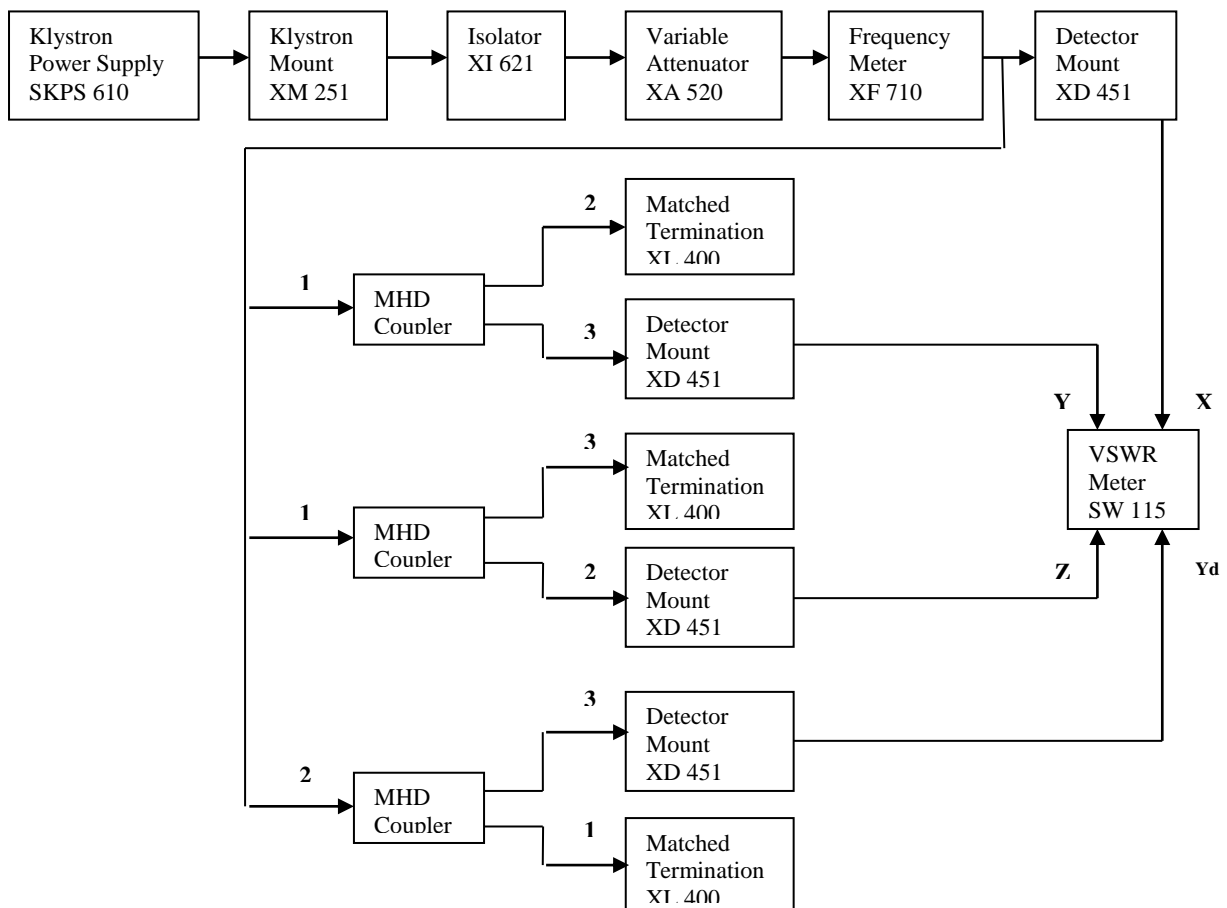

Fig: SET UP FOR STUDY OF MULTIHOLE DIRECTIONAL COUPLER

PROCEDURE

Measurement of coupling factor, insertion loss and Directivity:

- Set the equipment as shown in figure.
- Energize the microwave source for particular operation of frequency.
- Remove the MHD coupler and connect the detector mount to frequency meter
- Set any reference level of power on VSWR meter with the help of variable attenuator, gain control knob of VSWR meter and note down the reading.
- Insert the directional coupler as shown in fig with detector to auxiliary port 3 and matched termination to port 2 with out changing the position the position of variable attenuator and gain control knob of VSWR meter.
- Note down the readings of VSWR meter on the scale with the help of range dB switch is required, Let it be Y.
- Calculate coupling factor which will be X-Y in db.
- Now carefully disconnect the detector from oscillating port 3 and matched termination. From port 2 without disturbing the setup.
- Connect the matched termination to the auxiliary port 3 and detector to port2 and measure the reading on VSWR let it be Z.
- Compute insertion loss = X-Z in db.
- Repeat the step from 1 to 4.
- Connect the directional coupler in the reverse direction i.e. port 2 to frequency meter size; matched termination to port 1 and detector mount to port 3, without changing the position of the variable attenuator and gain control, knob of VSWR meter.
- Measure and note down the reading on VSWR meter .let it be Y_D .
- Compute the directivity as $Y - Y_D$.
- Repeat the same for other frequency and Note down the corresponding values from CRO.

PRECAUTIONS

- Beam voltage should not exceed 250V
- Reflected voltage should not exceed 270V
- Fan should be operated to reduce the heat for reflex klystron
- Every 20 minutes switch of the supply and set the initial conditions.
- Carefully follow the specifications of the devices and equipment.

OBSERVATIONS

INPUT X-(Port1) =
OUT PUT Y-(Port 31) =
OUT PUT Z-(Port 21) =
OUT PUT Y_d -(Port 32) =

C=Coupling factor = $IX - YI$ =

Insertion loss = $IX - ZI$ =

I=Isolation = $IX - Y_d I$ =

Directivity= $IY - Y_d I = I - C$ =

RESULT :Directivity, Coupling factor and Insertion loss of the Directional coupler are determine
Directivity=

Coupling factor=

Insertion loss=

VIVA QUESTIONS

1. What is the primary purpose of a directional coupler?
2. How far apart are the two holes in a simple directional coupler?
3. What is the purpose of the absorbent material in a directional coupler?
4. In a directional coupler that is designed to sample the incident energy, what happens to the two portions of the wavefront when they arrive at the pickup probe?
5. What happens to reflected energy that enters a directional coupler that is designed to sample incident energy?

9. STUDY OF ANTENNA TRAINER KIT

AIM: To arrange the trainer kit and perform the functional checks

APPARATUS:

- 1) Antenna Trainer
- 2) Motorized Antenna Unit
- 3) Receiving Unit Mast
- 4) RF detector
- 5) RPP 2661A (S/W)
- 6) Dual Probe/BNC Cable

BLOCK DIAGRAM:

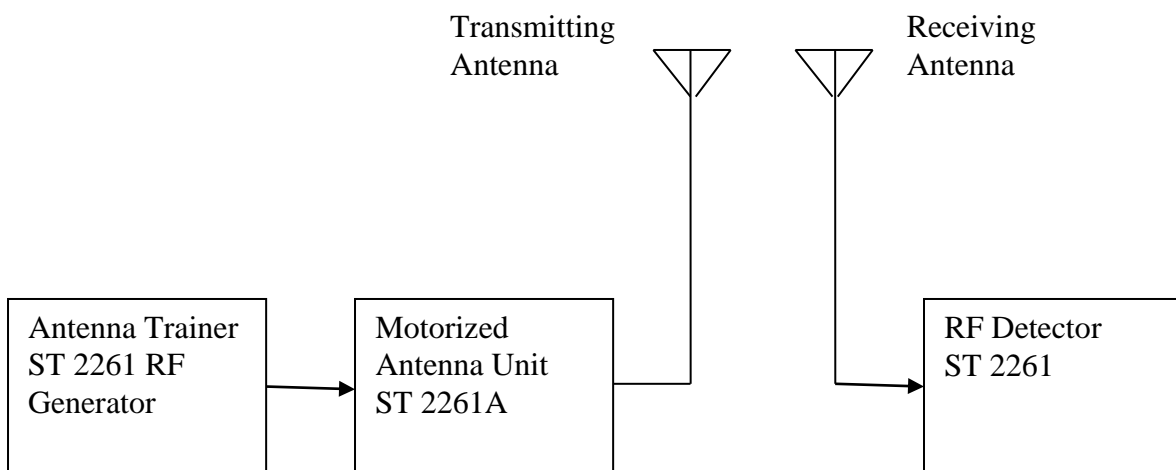

THEORY:

- Antenna impedance (Z_a): It is defined as the ratio of input voltage to input current (or) $Z_a = (V_i / I_i) \Omega$
- $Z_a = R_a + jX_a$, Here, the reactive part X_a results from fields surrounding the antenna. The resistance part R_a is given by $R_a = R_1 + R_r$.
 - R_1 represents losses in the antenna.
 - R_r is called radiation resistanceRadiation resistance R_r is defined as fictitious or hypothetical resistance that would dissipate an amount of power equal to the radiated power
$$R_r = \text{Power radiated} / I_{rms}^2$$
- Directional characteristics: These are also called radiation characteristics these are of two types
 - a) Field strength pattern: It is the variation of absolute value of field strength as a function of θ . E Vs θ is called field strength pattern
 - b) Power Pattern: It is the variation of radiated power with θ .

- Effective length of Antenna (L_{eff}): It is equal to the length of an equivalent linear antenna which radiates the same field strength as the actual antenna and the current is constant throughout the length of linear antenna. Effective length of an antenna is always less than actual length.
- Radiation Intensity: It is defined as the power radiation in the given direction per unit solid angle

$$RI = r^2 P = Y^2 E^2 / \eta \quad (\text{watt / unit solid angle})$$
- Directive gain: It is defined as the ratio of intensity of radiation in a specified direction to the average radiation intensity
- Directivity D : It is defined as the ratio of the maximum radiation intensity to the average radiation intensity
- Power gain: it is defined as the ratio of 4π times the radiation intensity to the total input power

$$g_p = 4\pi(RI)/W_t$$
- Antenna Efficiency : It is defined as the ratio of radiated power to the input power

$$H = W_r/W_t = W_r/(W_r+W_l) = g_p/g_p$$
- Affective Area :

$$A_e = (\lambda^2 / 4\pi) g_d \quad (\text{m}^2)$$
- Antenna Equiva lent Circuit : It is a series R_a , L_a and C_a
- Antenna Bandwidth: It is defined as the range of frequencies over which the antenna maintained its characteristics and parameter like gain, front to back ratio.
- Front to Back Ratio: It is defined as the ratio of radiated power in the desired direction to the radiated power in the opposite direction.
- Polarization: It is defined as the electric vector of the EM wave produced by an antenna.

PROCEDURE:

- Place the main unit on the table and connect power chord.
- RF generator: Adjust level potentiometer to middle position.
- Modulation generator: Select Switch to 'INT' position and adjust level potentiometer to the middle position.
- Install transmitting mast, place it beside the main unit and connect it is to main with 'RFOUT' using a BNC cable of 25" long.
- Install receiving mast and keep it at some distance from the transmitter mast.
- Place RF detector unit beside the receiving mast and connect it to the receiving mast and connect it to the receiving mast using a BNC to BNC cable of 25" long.
- Keep the base of the transmitting mast such that the '0' position of goniometer should be directed towards the RF detector and also align the masker of the mast with '0' position
- Install folded dipole antenna on transmitting mast. Keep its direction towards, receiving mast by rotating it in clock wise direction.
- Switch on the main unit and check the display in DPM of directional coupler. It will show some reading according to the level knob at starting

- Connect a 7.5V adapter to RF detector unit, switch it 'ON' Keep the level knob at middle position, it will show some reading according to level knob at starting (incase of overloading reduce it by level potentiometer of RF detector.)
- Now vary the F.S adjust potentiometer of directional coupler to make the display reading 100 μ amp. And then adjust the level of RF detector to show $\frac{3}{4}$ th reading of main unit display.
- Rotate the transmitting antenna between 0 to 360 and observe the display at RF detector. The variations reading indicates that transmitter and receiver are working and radiation pattern is formed.

RESULT: The trainer kit is arranged and the functional checks are performed.

10.RADIATION PATTERN OF 3 ELEMENT YAGI-UDA FOLDED DIPOLE

AIM: To observe the radiation pattern of Yagi-Uda 3-element folded dipole.

APPARATUS:

- 1) Antenna Trainer
- 2) Motorized Antenna Unit
- 3) Receiving Unit Mast
- 4) RF detector
- 5) RPP 2661A (s/w)
- 6) Dual Probe/BNC Cable
- 7) Yagi-Uda 3-element folded dipole

BLOCK DIAGRAM:

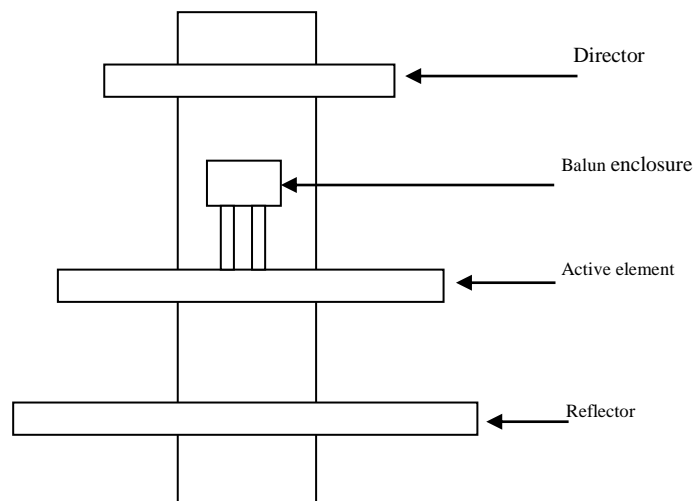
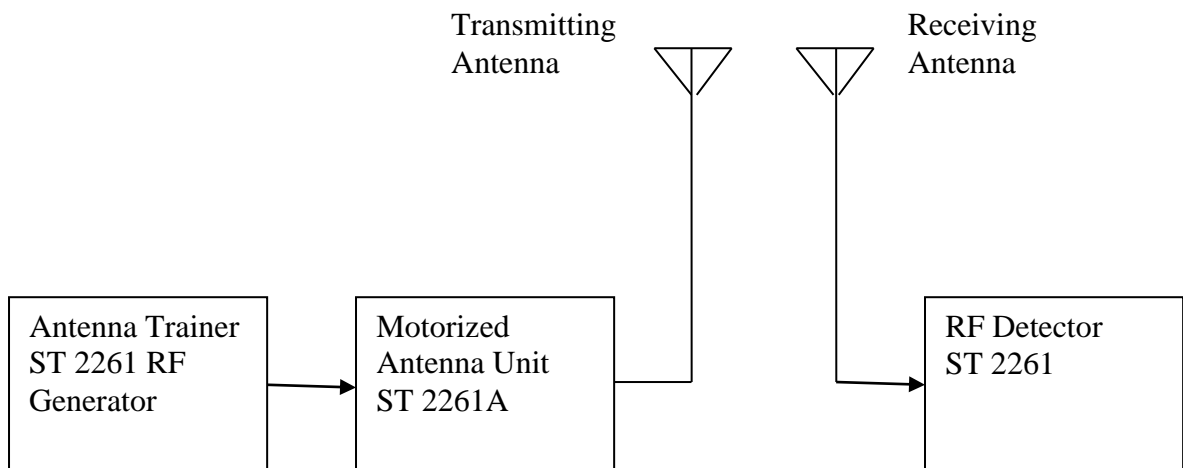

Fig: Yagi-Uda 3-element folded dipole

THEORY:

A Yagi-Uda antenna is familiar as the commonest kind of terrestrial TV antenna to be found on the roof top of houses. It is usually used at frequencies between 30MHz and 3GHz or a wavelength range of 10m to 10cm. The rod length each and the spacing of the element are about 1/3 of wavelength. There are three kinds of elements (or rods) mounted on a longitudinal connecting bar or rod. Its doesn't matter if this connecting rod conducts as it is oriented at right angles to currents in the elements, end to the radiating electric field it supports little or no current and doesn't contribute to radiation. The three types of elements are the driven element, reflector (3) and directors only the driving element is connected to the feeder the either elements coupled to the transmitter power through the local electromagnetic fields which induce currents in them. The driven element is often a folded dipole which by itself would have a driving point impedance of about 300Ω to the feeder but it is reduced by the shunting effect of other elements so a typical Yagi-Uda has driving point impedance in the range 20-90 Ω . The maximum gain of a Yagi-Uda antenna is limited to an amount given approximately by the gain of a dipole (1.66) times the total number of elements

PROCEDURE:

- Mount Yagi-Uda 3 element folded dipole antenna on the top of transmitting antenna.
- Main Unit: Place the main unit on the table and connect power chord.
RF generator: Adjust level potentiometer to middle position.
Directional coupler: Select the switch to 'FSADJ'; potentiometer to middle position
- Install transmitting mast and keep it at some distance from the receiver mast.
- Install receiving mast and keep it at some distance from the transmitter mast
- Place RF detector unit beside the receiving mast and connect it to the receiving mast using a BNC to BNC
- Keep the base of the transmitting mast such that '0' position of goniometer should be directed towards the RF detector and also align the marker of the mast with '0' position.
- Install detector antenna on the RX mast, keep its direction towards the transmitter mast by rotating it in counter clock wise direction.
- Install folded dipole antenna on the transmitter mast keep its direction towards the receiver mast by rotating it in counter clock wise direction.
- Switch on the main unit and check the display in DPM of directional coupler. It will show some reading according to its level knob at starting.
- Connect a 7.5V adapter to the RF detector unit, switch it ON and keep the level knob at middle position. It will show some reading according to its level knob at starting (Incase of over loading, reduce it level potentiometer of a RF detector.)
- Now vary the RF's adjust the potentiometer of directional coupler to make the display reading 100 μ A and then adjust the level of RF detector to show the $\frac{3}{4}$ reading of the main unit display.
- Rotate the transmitting antenna between 0° - 360° and observe the display at RF detector. The variation in reading indicates that the transmitter and receiver are working and radiation patterns formed.

OBSERVATIONS

Beam width=

Maximum Gain=

Side lobe Angle=

Angle(θ)	Power(dB)	Current (μ A)

GRAPH:

Now do plot the polar graph for the transmitting antenna, start tracking the reading at the interval of 5° to 10° and note the reading of RF detection display.

RESULT:

Hence the radiation pattern of 3 element Yagi-Uda element has been observed and plotted.

Beam Width=

Maximum Gain=

Side lobe angle=

VIVA QUESTIONS

1. What is the length of the director when compared to the driven element?
2. What should be the distance between the two directors in Yagi- Uda?
3. Mention few applications of Yagi Uda element?
4. Is yagi uda antenna a narrow band or a broad band element . Why?
5. Explain the importance of the folded dipole in the Yagi- Uda array?

11.RADIATION PATTERN OF 5 ELEMENT YAGI-UDA FOLDED DIPOLE

AIM: To observe the radiation pattern of Yagi-Uda 5-element folded dipole.

APPARATUS:

- 8) Antenna Trainer
- 9) Motorized Antenna Unit
- 10) Receiving Unit Mast
- 11) RF detector
- 12) RPP 2661A (s/w)
- 13) Dual Probe/BNC Cable
- 14) Yagi-Uda 5-element folded dipole

BLOCK DIAGRAM:

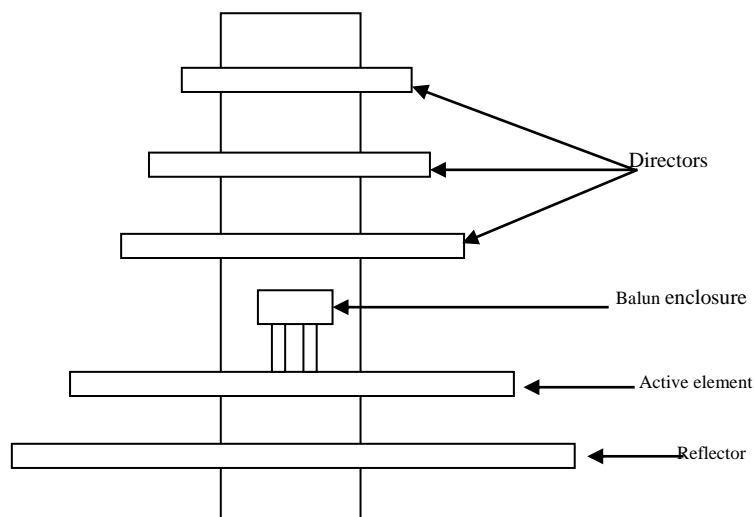
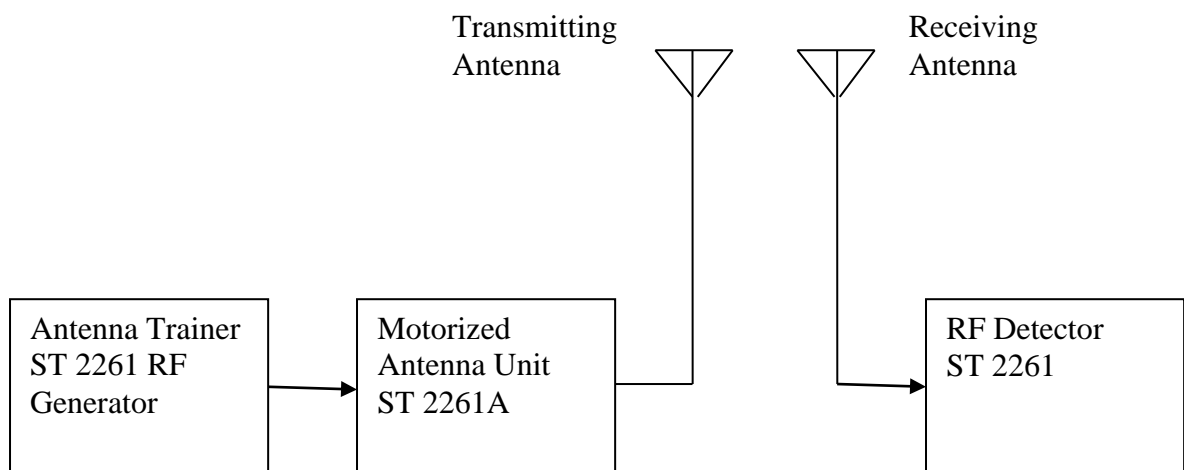

Fig: Yagi-Uda 5-element folded dipole

THEORY:

A yagi-uda antenna or array is a directional antenna consisting of a driven element and additional parasitic element. The reflector element is slightly longer (5%) than driven dipole and the directors are shorter. This design has an increase in directionality and gain compared to a simple dipole. Highly directional antennas like yagi-uda are referred to as 'Beam antennas': due to high gain, but over a rather narrow band width. The lengths of directors are smaller than of the reflectors according to an elaborate design procedure. The elements are usually parallel in one plane, supported on a single crossbar in one plane, supported on a single cross bar known as boom. The driven element typically a $\lambda/2$ dipole or folded dipole is directly excited. All the elements are considered parasitic and they reradiate power which they receive from the driver element. The parasitic element can be considered as a dipole with a gap at its centre, feed point, now instead of attaching the antenna to the lead, we connect it to short circuit which reflects all of the incident power 180° out of phase.

PROCEDURE:

- Mount Yagi-Uda 5-element folded dipole antenna on the top of transmitting antenna.
- Main Unit: Place the main unit on the table and connect power chord.
RF generator: Adjust level potentiometer to middle position.
Directional coupler: Select the switch to 'FSADJ'; potentiometer to middle position
- Install transmitting mast and keep it at some distance from the receiver mast.
- Install receiving mast and keep it at some distance from the transmitter mast
- Place RF detector unit beside the receiving mast and connect it to the receiving mast using a BNC to BNC
- Keep the base of the transmitting mast such that '0' position of goniometer should be directed towards the RF detector and also align the marker of the mast with '0' position.
- Install detector antenna on the RX mast, keep its direction towards the transmitter mast by rotating it in counter clock wise direction.
- Install folded dipole antenna on the transmitter mast keep its direction towards the receiver mast by rotating it in counter clock wise direction.
- Switch on the main unit and check the display in DPM of directional coupler. It will show some reading according to its level knob at starting.
- Connect a 7.5V adapter to the RF detector unit, switch it ON and keep the level knob at middle position. It will show some reading according to its level knob at starting (In case of over loading, reduce its level potentiometer of a RF detector.)
- Now vary the RF's adjust the potentiometer of directional coupler to make the display reading $100\mu\text{A}$ and then adjust the level of RF detector to show the $\frac{3}{4}$ reading of the main unit display.
- Rotate the transmitting antenna between 0° - 360° and observe the display at RF detector. The variation in reading indicates that the transmitter and receiver are working and radiation patterns formed.

OBSERVATIONS

Beam width=

Maximum Gain=

Side lobe Angle=

Angle(θ)	Power(dB)	Current (μ A)

GRAPH:

Now do plot the polar graph for the transmitting antenna, start tracking the reading at the interval of 5° to 10° and note the reading of RF detection display.

RESULT:

Hence the radiation pattern of 5 element Yagi-Uda element has been observed and plotted.

Beam Width=

Maximum Gain=

Side lobe angle=

VIVA QUESTIONS

1. What is the length of the reflector when compared to the driven element?
2. What are the pro and cons or 5 element Yagi-Uda antenna when compared to 3 element Yagi-Uda antenna
3. Arrange the lengths of the reflector ,director and driven element in an order
4. If a dipole is used as a feed element in the Yagi- Uda array then than what is the impedance of the dipole element?

12.RADIATION PATTERN OF $\lambda/2$ PHASED ARRAY ANTENNA

AIM: To observe the radiation pattern of $\lambda/2$ phased array antenna.

APPARATUS:

- 1) Antenna Trainer
- 2) Motorized Antenna Unit
- 3) Receiving Unit Mast
- 4) RF detector
- 5) RPP 2661A (s/w)
- 6) Dual Probe/BNC Cable
- 7) $\lambda/2$ phased array antenna

BLOCK DIAGRAM:

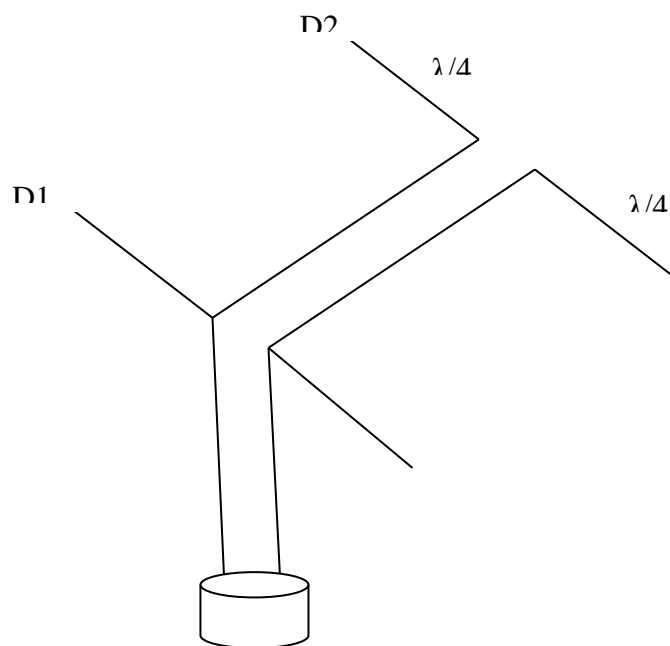
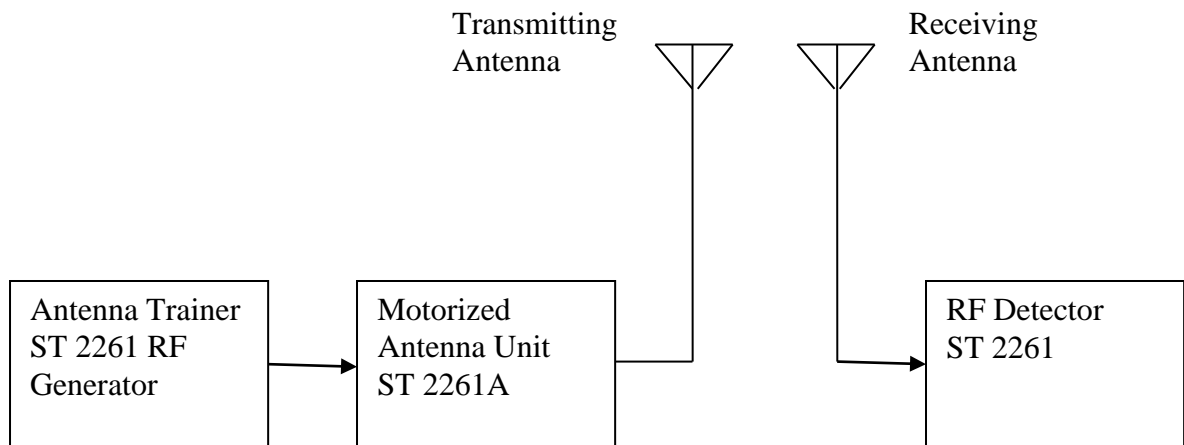

Fig: $\lambda/2$ phased array antenna

THEORY:

A phased array is an array of antennas in which the relative phases of the respective signals feeding the antennas are varied in such a way that the effective radiation pattern of the array is reinforced in a desired direction and suppressed in undesired directions. An antenna array is a group of multiple active antennas coupled to a common source or load to produce a directive radiation pattern. Usually the spatial relationship of the individual antennas contributes to the directivity of the antenna array use of term “active antenna” is intended to describe elements whose energy output is modified due to presence of a source energy in the element or an element in which the energy in the element or an element in which the energy output from a source of energy is controlled by a signal input. One common application of this is which a standard multiband television camera antenna which multiple elements coupled together. IN a broad cast engineering phased arrays are required to be used by many AM broadcast radio stations to enhance signal strengths and therefore coverage in the city of license, while minimizing interference to the other areas. Phased array radars are usually used by warship also.

PROCEDURE:

- Mount $\lambda/2$ phased array antenna on the top of transmitting antenna.
- Main Unit: Place the main unit on the table and connect power chord.
RF generator: Adjust level potentiometer to middle position.
Directional coupler: Select the switch to ‘FSADJ; potentiometer to middle position
- Install transmitting mast and keep it at some distance from the receiver mast.
- Install receiving mast and keep it at some distance from the transmitter mast
- Place RF detector unit beside the receiving mast and connect it to the receiving mast using a BNC to BNC
- Keep the base of the transmitting mast such that ‘0’ position of goniometer should be directed towards the RF detector and also align the marker of the mast with ‘0’ position.
- Install detector antenna on the RX mast, keep its direction towards the transmitter mast by rotating it in counter clock wise direction.
- Install folded dipole antenna on the transmitter mast keep its direction towards the receiver mast by rotating it in counter clock wise direction.
- Switch on the main unit and check the display in DPM of directional coupler. It will show some reading according to its level knob at starting.
- Connect a 7.5V adapter to the RF detector unit, switch it ON and keep the level knob at middle position. It will show some reading according to its level knob at starting (In case of over loading, reduce it level potentiometer of a RF detector.)
- Now vary the RF’s adjust the potentiometer of directional coupler to make the display reading $100\mu\text{A}$ and then adjust the level of RF detector to show the $\frac{3}{4}$ reading of the main unit display.
- Rotate the transmitting antenna between 0° - 360° and observe the display at RF detector. The variation in reading indicates that the transmitter and receiver are working and radiation patterns formed.

OBSERVATIONS

Beam width=

Maximum Gain=

Side lobe Angle=

Angle(θ)	Power(dB)	Current (μ A)

GRAPH:

Now do plot the polar graph for the transmitting antenna, start tracking the reading at the interval of 5° to 10° and note the reading of RF detection display.

RESULT:

Hence the radiation pattern of $\lambda/2$ phased array antenna has been observed and plotted.

Beam Width=

Maximum Gain=

Side lobe angle=

VIVA QUESTIONS

1. What are the application of the phased array element
2. What is a broad side array
3. What is an end fire array
4. What is a binomial array and explain how the elements are excited?
5. What is the maximum and minimum spacing between the elements in a broad side array.

13. MAGIC – TEE AS MIXER

AIM: To construct a Mixer using Magic - Tee.

APPARATUS:

- 1) Micro wave source ----- 2 No's
- 2) Klystron Mount ----- 2 No's
- 3) Isolator ----- 2 No's
- 4) Variable Attenuator ----- 2 No's
- 5) Magic – Tee ----- 1 No
- 6) Matched termination ----- 1 No

PROCEDURE:

- Arrange the bench setup as shown in fig.
- Apply the signal 1 at port 4, signal 2 at port 3 of the Magic – Tee.
- Measure the output signal at port 2.
- From the output verify the Mixer operation.

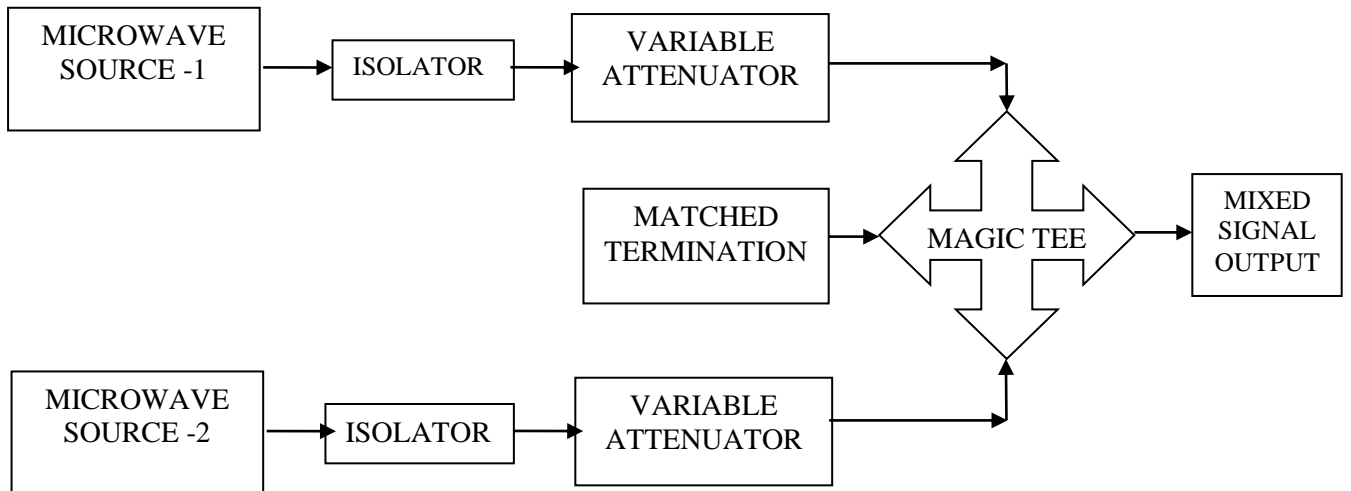

BENCH SETUP DIAGRAM OF MIXER:

RESULT:

Thus Mixer using Magic – Tee was constructed and verified.

14. CIRCULATOR AS MIXER

AIM:

To construct a Mixer using Circulator.

APPARATUS:

1. Micro wave source ----- 2 No's
2. Klystron Mount ----- 2 No's
3. Isolator ----- 2 No's
4. Variable Attenuator ----- 2 No's
5. Circulator ----- 1 No
6. Power Detector ----- 1 No's

PROCEDURE:

1. Arrange the bench setup as shown in fig.
2. Apply the signal 1 at port 1 and signal 2 at port 3 of the circulator.
3. Measure the output signal at port 2.
4. From the output verify the Mixer operation.

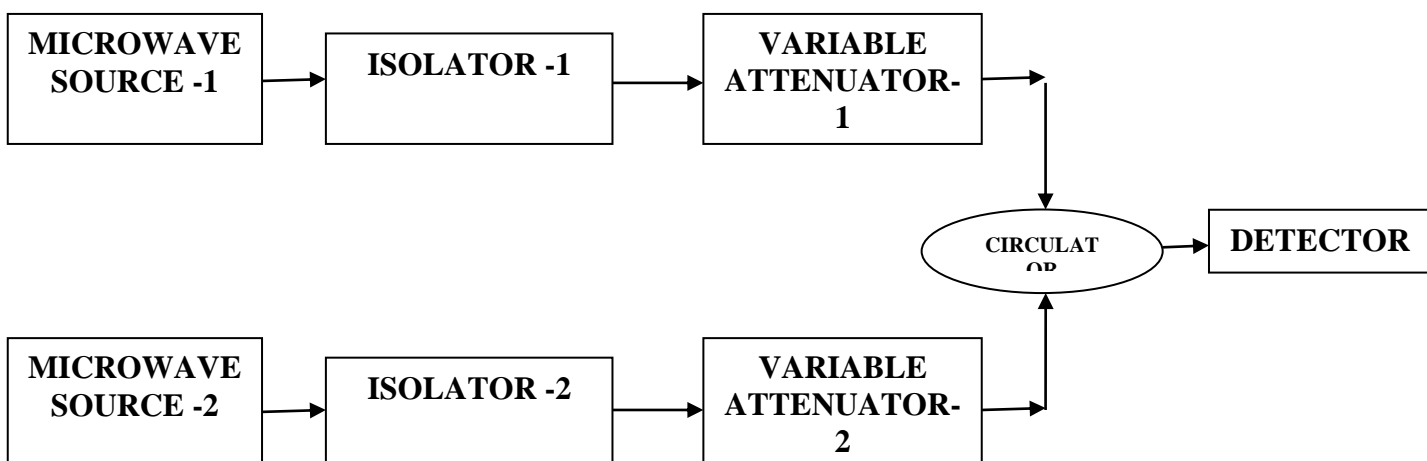

BENCH SETUP DIAGRAM OF CIRCULATOR AS DUPLEXER

RESULT:

Thus Mixer using Circulator was constructed and verified.

VIVA QUESTIONS

1. What are the two basic types of Tee junctions?
2. Why is the E-type Tee junction so named?
3. What is the output and the primary arms if the input is fed at the Tee arm of the H-plane T junction
4. What is the length of the slot in the E-Plane Tee junction
5. The magic-T is composed of what two basic types of T junctions?
6. Why is the hybrid T called as a magic Tee junction?
7. What are the primary disadvantages of the magic-Tee?
8. What type of junctions are formed where the arms of a hybrid ring meet the main ring?
9. Hybrid rings are used primarily for what purpose?

15. WAVE GUIDE PARAMETERS MEASUREMENT

AIM:

To measure the Q – factor of the given wave guide.

COMPONENTS REQUIRED:

1. Microwave source (klystron power supply)
2. Klystron Mount
3. Isolator
4. Variable Attenuator
5. Frequency meter
6. DUT
7. Power Detector

PROCEDURE:

1. Arrange the bench setup as shown in figure.
2. Vary the signal frequency in such a way that the maximum output is obtained in the detector.
3. This is due to the fact that DUT is having resonant frequency f_0 .
4. Now vary the frequency to obtain the half power frequency by varying the frequency of the signal.
5. In the similar way find other frequency end.
6. Using lower and upper cut – off frequencies calculate the bandwidth and Q – factor using the below equation.

$$Q = f_0 / \text{bandwidth}$$

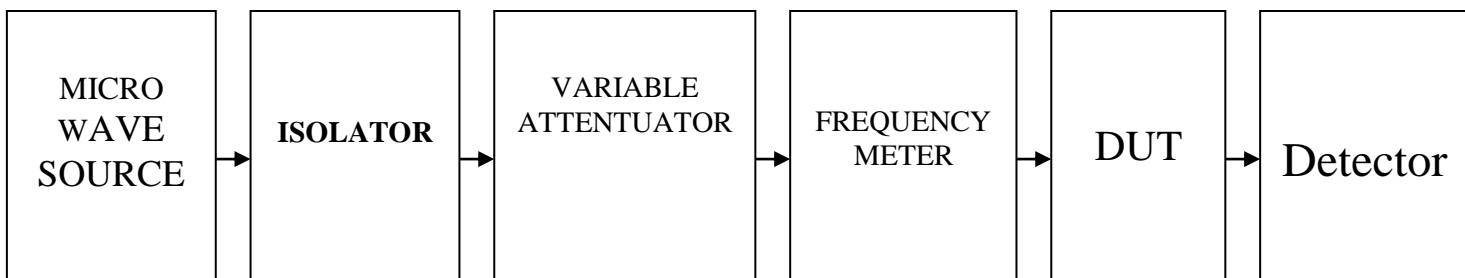

BENCH SETUP DIAGRAM OF WAVE GUIDE PARAMETERS MEASUREMENT

RESULT: Thus the Q – factor of the given cavity was determined and verified.

16. DESIGN OF RECTANGULAR MICROSTRIP PATCH ANTENNA WITH COAXIAL PROBE FEEDING

AIM

To design and simulate rectangular microstrip patch antenna with coaxial probe feeding technique for the frequency $f=3.5\text{GHz}$.

SOFTWARE REQUIRED

HFSS 13.0 software in PC.

THEORY

HFSS is a commercial finite element method solver for electromagnetic structures from ANSYS. ANSYS HFSS is a 3D electromagnetic simulation software for designing and simulating high frequency electronics products such as antennas, antenna arrays, RF or microwave components, high speed interconnects, filters, connectors, IC packages and printed circuit boards. Engineers worldwide use ANSYS HFSS to design high frequency, high speed electronics found in communications systems, radar systems, advanced driver assistance systems, satellites, internet of things (IOT) products and other high speed RF and digital devices.

ANSYS HFSS is the premier EM tool for R&D and virtual design prototyping. It reduces design cycle time and boosts your products reliability, and performance. HFSS is synonymous with gold standard accuracy and reliability for tracking 3D EM challenges by virtue of its automatic adaptive meshing technique and sophisticated solvers, which can be accelerated through high performance computing technology.

Microstrip Patch antennas can be fed by a variety of methods. These methods can be classified into 2 categories.

1. Contacting method: The RF power is fed directly to the radiating patch using connecting elements such as a microstrip line or coaxial probe.
2. Non Contacting method: Electromagnetic field coupling is done to transfer power between the microstrip line & the radiating patch such as aperture coupling and proximity coupling.

Coaxial Probe feed:

Coaxial feeding is feeding method in which that the inner conductor of the coaxial is attached to the radiation patch of the antenna while the outer conductor is connected to the ground plane. Due to its advantages such as easy of fabrication and low spurious radiation, we use this feeding technique. It introduces an inductance into the feed that may need to be taken into account if the height h gets large.

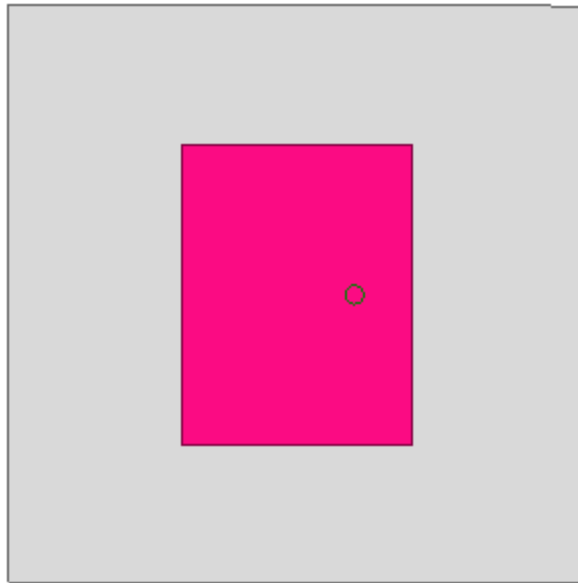

Fig.1: Coaxial Probe feed Microstrip Patch Antenna

PROCEDURE

- Open HFSS software and Insert new HFSS design.
- Adjust the co-ordinates.
- Create a ground plane(Rectangular 2D).
- Create a dielectric substrate with FR4_Epoxy material with same size of ground plane with z-height 1.6mm.
- Create patch and coaxial stripline of given dimensions.
- Create coaxial feed by:
 - a) Creating the slot on the ground plane, circle shape
 - b) Click on cylinder and create outer part of feed.
 - c) Click on cylinder and give dimensions as pin (inner part of coaxial touching the ground).
 - d) Click on cylinder and give dimensions as probe.
 - e) Pin and probe are pec material.
 - f) Then close the circle slot by taking circle shape.
- Then give feed at the closed circle (wave port).
- Now give the perfect E to ground and patch.
- Then create radiation box on the ground and give radiation. The radiation should be given to all the faces except at ground.
- Assign frequency and no. of passes.
- Now add freq sweep – fast – linear count.
- Now check validation and analyze all.
- Then go to results – Create model solution – rectangular plot – new report. Plot both Return loss and VSWR.

- Then click HFSS – click radiation – click far field – infinite sphere and give values to phi and theta.
- Then click on results and create far field.
- Click plot of 3D – gain-dB – new report.

DESIGN CONSIDERATIONS

Parameters	Width	Length	Height	Position
Ground plane	60mm	60mm	-	(-30,-30,0)
Dielectric	60mm	60mm	1.6mm	(-30,-30,0)
Patch	26.082mm	19.987mm	-	(-13.041,-9.9935, 1.6)
Radiation box	60mm	60mm	100mm	(-30,-30,0)
Parameters	Radius	Height	Position	
Slot	1.6	-	(0,5,0)	
Coax	1.6	-2	(0,5,0)	
Pin	0.8	-2	(0,5,0)	
Probe	0.8	1.6	(0,5,0)	
Closed slot/source	1.6	-	(0,5,-2)	

PRECAUTIONS

- Make sure whether the excitation is correctly given or not.
- Make sure about the given boundaries and the feed should be given properly.

RESULT

Designed and simulated rectangular patch antenna with coaxial feed and observed the Return loss, VSWR and Gain plots.

For freq=3.4422GHz,
 Return loss (dB): -17.3482
 VSWR: 1.3231
 Gain: 3.9916dB

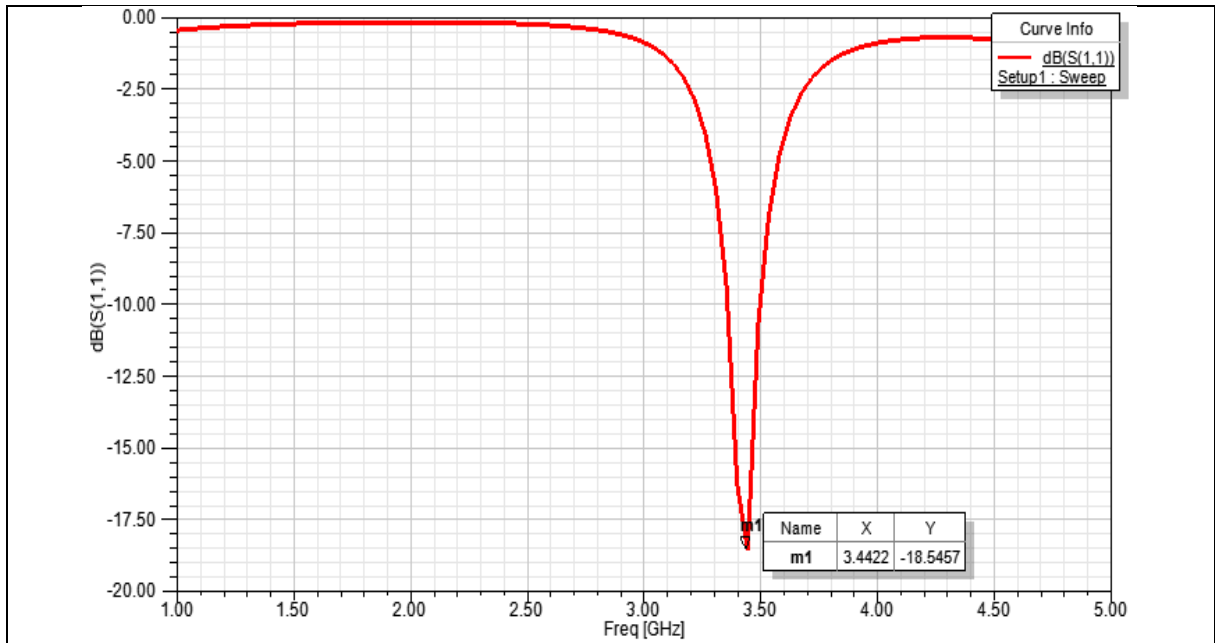

Fig.2: Return Loss Plot

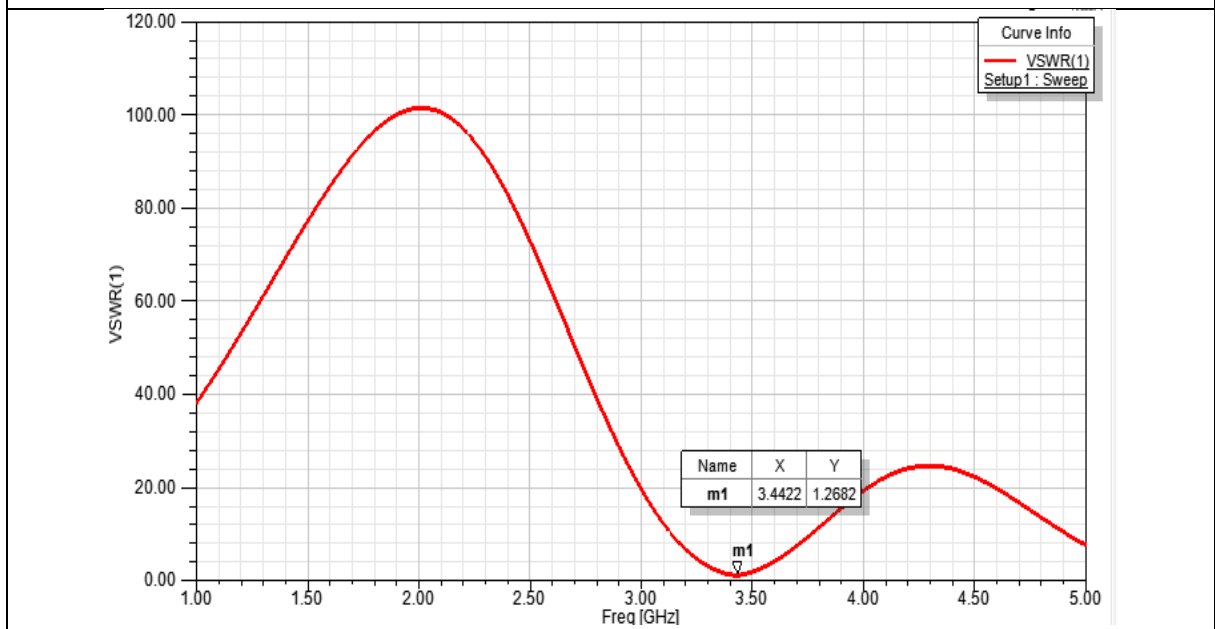
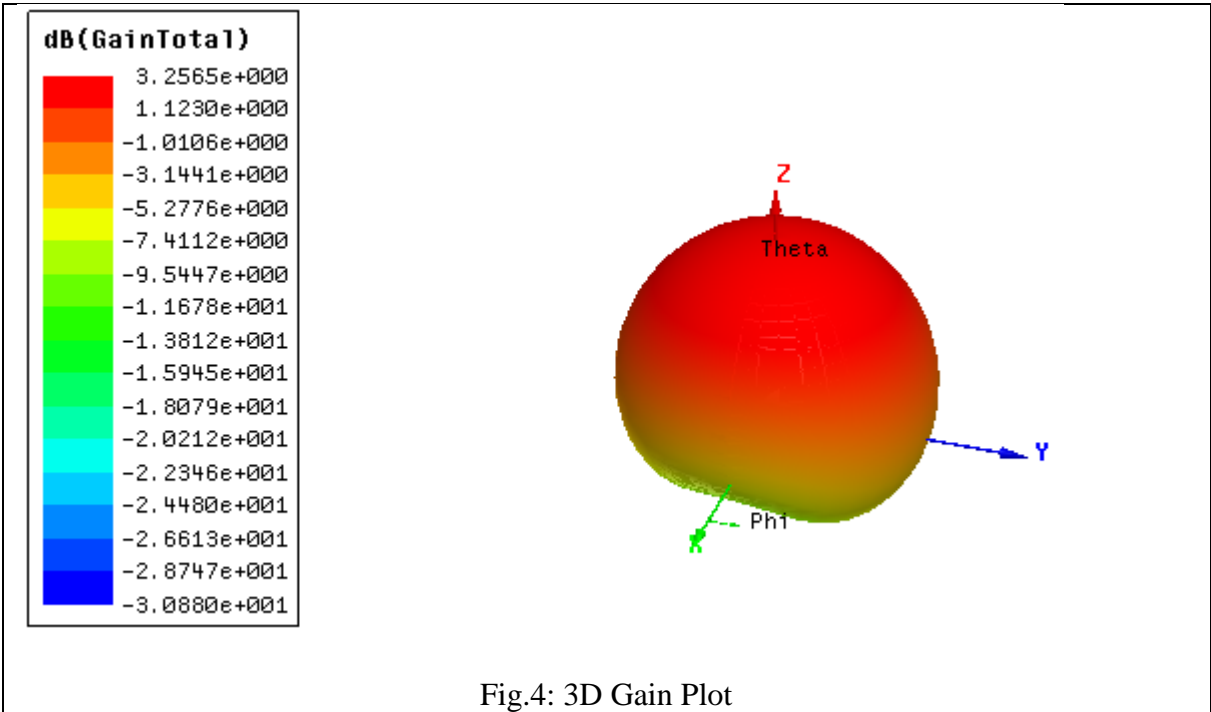

Fig.3: VSWR Plot



17. DESIGN OF RECTANGULAR MICROSTRIP PATCH ANTENNA USING STRIPLINE FEED

AIM

To design and simulate rectangular microstrip patch antenna for the frequency 3GHz using stripline feed.

SOFTWARE REQUIRED

HFSS 13.0 software in PC.

THEORY

Microstrip patch antennas have more advantages and better prospects compared to conventional antennas, such as lighter in weight, low volume, low cost, low profile, smaller in dimension and ease of fabrication and conformity. Moreover, the microstrip patch antennas can provide frequency agility, broad band-width, feedline flexibility and beam scanning omnidirectional patterning. In its basic form, a microstrip Patch antenna consists of a radiating patch on one side of a dielectric substrate which has a ground plane on the other side.

The patch is normally made of conducting material such as copper or gold and can take any possible shape. The radiating patch and the feed lines are usually photo etched on the dielectric substrate.

Feeding Techniques to Microstrip Antennas:

The four most popular feed techniques used are the microstrip line, coaxial probe (both contacting schemes), aperture coupling and proximity coupling (both noncontacting schemes).

Microstrip (Offset Microstrip) Line Feed

In this type of feed technique, a conducting strip is connected directly to the edge of the microstrip patch. The conducting strip is smaller in width as compared to the patch. This kind of feed arrangement has the advantage that the feed can be etched on the same substrate to provide a planar structure. An inset cut can be incorporated into the patch in order to obtain good impedance matching without the need for any additional matching element. This is achieved by properly controlling the inset position.

Hence this is an easy feeding technique, since it provides ease of fabrication and simplicity in modeling as well as impedance matching. However as the thickness of the dielectric substrate increases, surface waves and spurious feed radiation also increases, which hampers the bandwidth of the antenna. This type of feeding technique results in undesirable cross polarization effects.

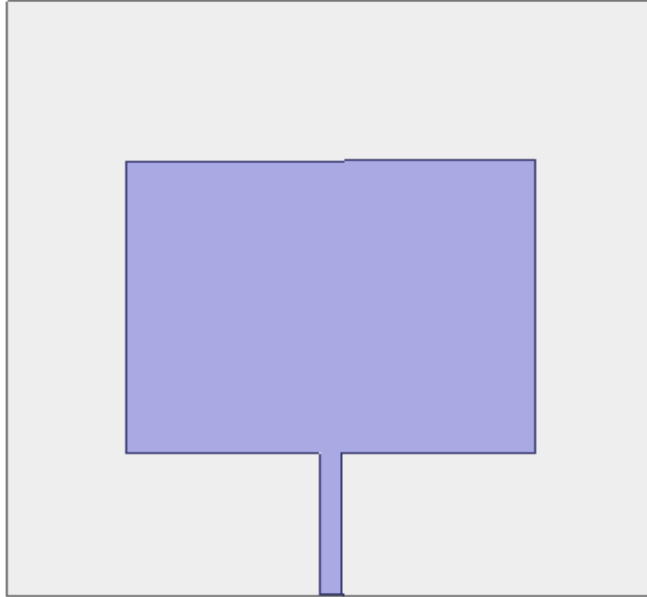

Fig.1: Rectangular microstrip patch antenna fusing stripline feed.

PROCEDURE

- Open HFSS software in PC and click on to insert HFSS design.
- Adjust the coordinate axis system in xy plane.
- Create a ground plane by click on rectangle and give dimensions.
- Create a dielectric box by click on box and give dimensions.
- Create a patch by click on rectangle and give dimensions and create stripline by click on rectangle and unite both.
- Click on HFSS -click on analysis setup then give frequency and number of passes then click on add solution sweep give fast and linear count.
- Create feed by click on rectangle in zx plane and give dimensions and excitation as lumped port.
- Give perfect e boundary condition to both ground and patch.
- Create radiation box by click on box and give dimensions and radiation to it.
- Click on validation check.
- Then click on analyze all.
- Now click on results-create model solution-plot both return loss and vswr.

CALCULATIONS

$V_0=3*10^8$ m/s, $f_r=3$GHz, for FR4 epoxy $\epsilon_r=4.4$, $h=1.6$mm	
Width $= (V_0/2f_r) * ((2/(\epsilon_r+1))^{1/2})$ $= ((3*10^8)/(2*3*10^9)) * ((2/(4.4+1))^{1/2})$	= 30.423mm
ϵ_{reff} $= ((\epsilon_r+1)/2) + (((\epsilon_r-1)/2) * [1+12*(h/w)]^{-1/2})$ $= ((4.4+1)/2) + (((4.4-1)/2) * [1+12*(1.6m/30.423m)]^{-1/2})$	= 4.031 mm
Δl $= 0.412h * ((\epsilon_{\text{reff}}+0.3) * ((w/h)+0.264)) \div ((\epsilon_{\text{reff}}-0.258) * ((w/h)+0.8))$ $= 0.412 * 1.6m * ((4.031+0.3) * ((30.423m/1.6m)+0.264)) \div ((4.4-0.258) * ((30.423m/1.6m)+0.8))$	= $7.3622*10^{-4}$ mm
L $= C/(2f_r(\epsilon_{\text{reff}})^{1/2}) - 2\Delta l$ $= (3*10^8)/(2*3*10^9(4.4)^{1/2}) - 2*7.3622*10^{-4}$	= 23.43mm.

DESIGN CONSIDERATIONS

Parameter	Width(x)	Length(y)	Height(z)	Position
Ground plane	50mm	50mm	-	-25,-25,0
Dielectric	50mm	50mm	1.6mm	-25,-25,0
Patch	30.423mm	23.43mm	-	-15.2115,-11.715,1.6
Stripline feed	2mm	-14mm	-	-1,-14,1.6
Radiation box	100mm	100mm	30mm	-50,-50,-15

PRECAUTIONS

- Make sure whether the excitation is correctly given or not.
- Make sure about the given boundaries and the feed should be given properly.

RESULT

Designed and simulated rectangular patch antenna using stripline feed and observed the Return loss, VSWR plots.

For frequency=2.9447GHz,

Return loss (dB): -23.0256

VSWR: 1.1519

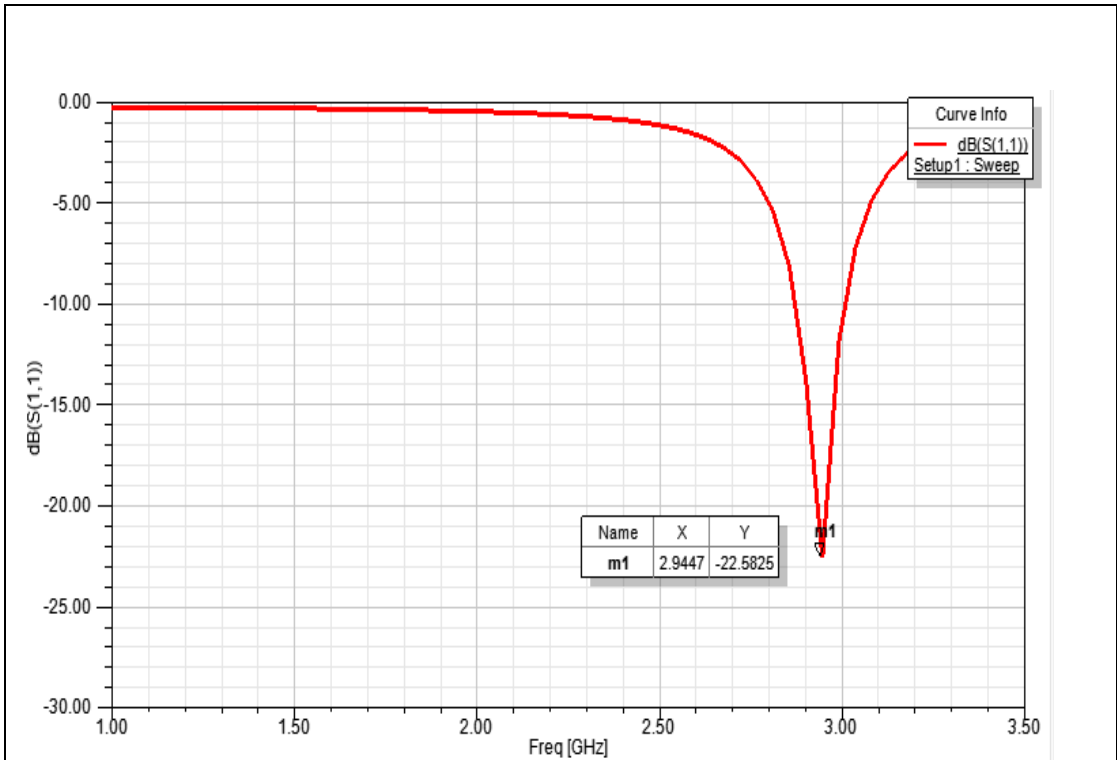

Fig.2: Return Loss Plot

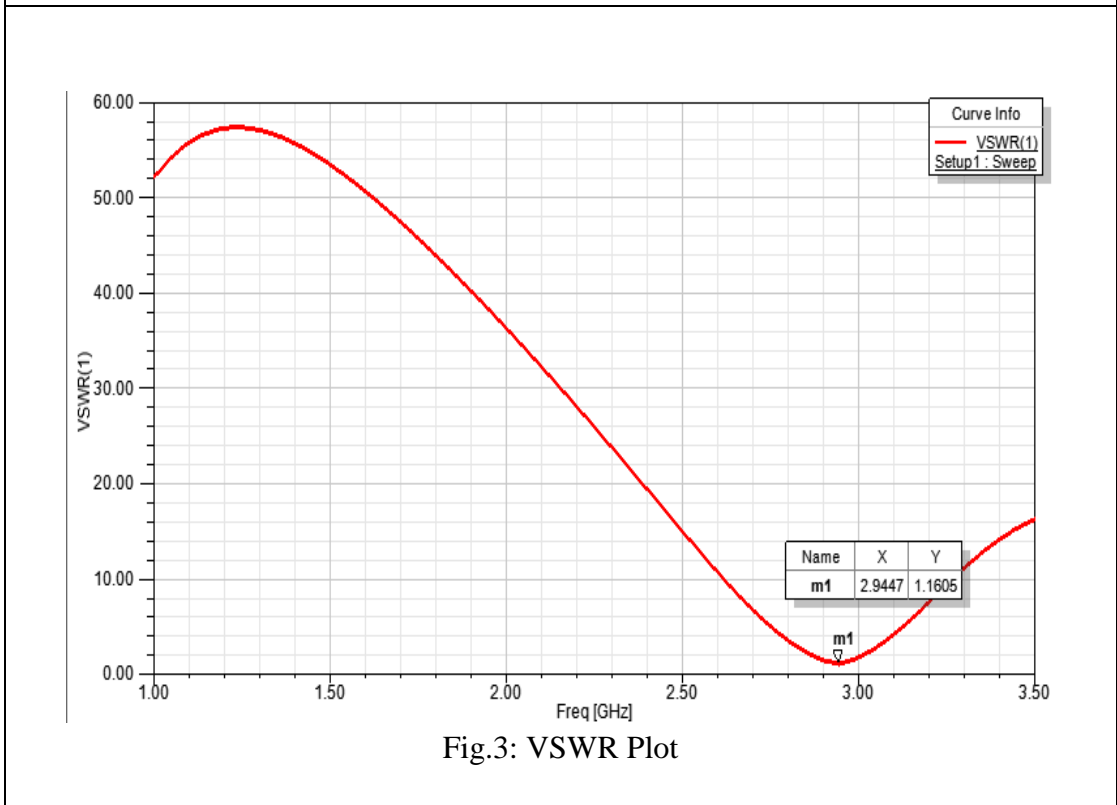

Fig.3: VSWR Plot

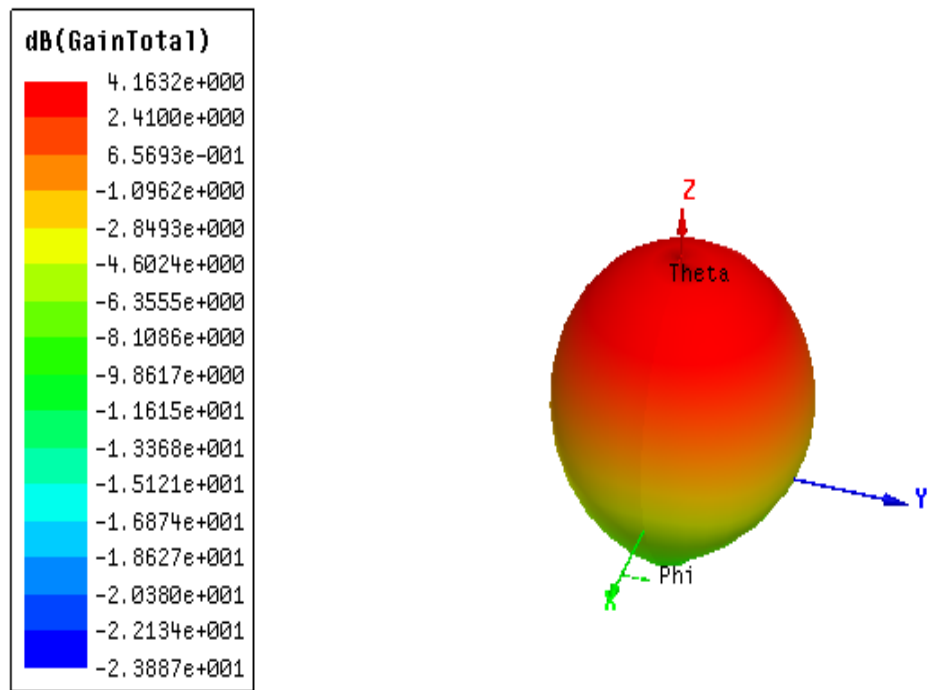

Fig.4: 3D Gain Plot

18. DESIGN OF RECTANGULAR MICRO STRIP PATCH ANTENNA WITH U-SHAPED SLOT FED WITH STRIP LINE

AIM

To design and simulate U-shaped Slot Rectangular Micro strip Patch Antenna with strip line feed working at operational frequency 5 GHz

APPARATUS

HFSS 13.0 installed P.C

THEORY

HFSS is a commercial [Finite Element Method](#) solver for electromagnetic structures from [ANSYS](#). The acronym stands for high-frequency structure simulator. HFSS is one of several commercial tools used for [antenna](#) design, and the design of complex [RF electronic circuit](#) elements including filters, transmission lines, and packaging.

U-shaped slot micro strip patch antenna operates at the multiple frequencies of 7.5 GHz and 5 GHz. This antenna has the capability of wide bandwidth and for dual band applications. The substrate used for making antenna is FR4-epoxy that has a relative permittivity of 4.4 and having a dielectric loss tangent of 0.02.

In this experiment strip line feeding technique is used. In strip line feeding, a strip like structure from the patch to the substrate is placed and then lumped port is assigned to it (XZ-axis). In this experiment parameters like gain, directivity and return loss of U-shaped slot micro strip patch antenna which are analysed and simulated.

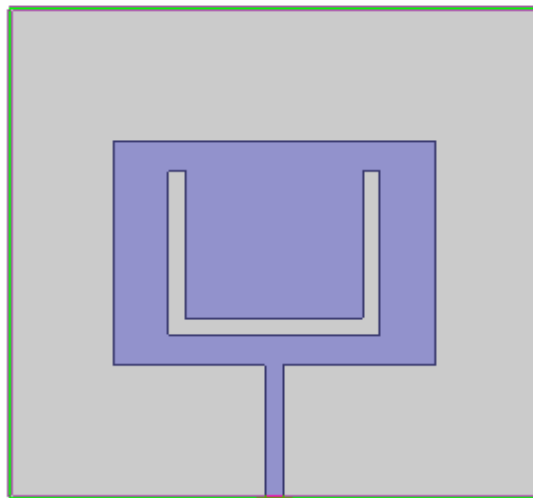

Fig.1: U-shaped Slot Rectangular Micro strip Patch Antenna with strip line feed

PROCEDURE

- Open HFSS software and insert new HFSS software.
- Create a ground plane using rectangle.
- Create dielectric box with same dimensions of ground and Z as 1.6mm and make material as FR4-epoxy.
- Create Patch and make a U slot on it by using 3 rectangles. First unite them and then subtract them from the patch
- Create strip line of given dimensions and give excitation as perfect E.
- Now create a feed along ZX plane of given dimensions and apply feed i.e., lumped port. Verify whether line is defined or not.
- Now create a radiation box such that antenna is exactly at its middle and excite box with radiation.
- Now go to analysis setup-add operating frequency and number of passes
- Now add frequency sweep i.e., fast and linear count
- Go for validate check, if all are correct then click on analyse all
- For results go to HFSS -> create model solution -> rectangular plot -> new plot for reflection coefficient and return loss
- For gain plot first go to HFSS -> radiation -> far field radiation and adjust
 - Start and stop values of phi and theta as -180 degrees to 180 degrees and 0 to 360 degrees respectively. Step size as 10 for phi and 5 for theta
- Again go to results-> create far field report-> 3D polar plot->Gain
- Observe the output graphs, verify the frequency and corresponding value

DESIGN CONSIDERATIONS

PARAMETER	WIDTH(X)	LENGTH(Y)	HEIGHT(Z)	POSITION
Ground	30	30	-	-15,-15,0
Dielectric	30	30	1.6	-15,-15,0
Patch	18.253	13.763	-	-9.12,-6.88, 1.6
Feed line	10	-9	-	-0.5,-6,1.6
Radiation box	80	80	40	-40,-40,-20
Rectangle 1	1	-10	-	-6,5,1.6
Rectangle 2	-1	-8	-	6,5,1.6
Rectangle 3	11	-1	-	-5,-4,1.6

PRECAUTIONS

- Make sure all excitations are given.
- Make sure outer box is excited with radiation box.

RESULT

A U shaped slot patch micro strip feed patch antenna is designed simulated at operating frequency of 5GHz using HFSS and output graphs of return loss, VSWR and Gain are verified.

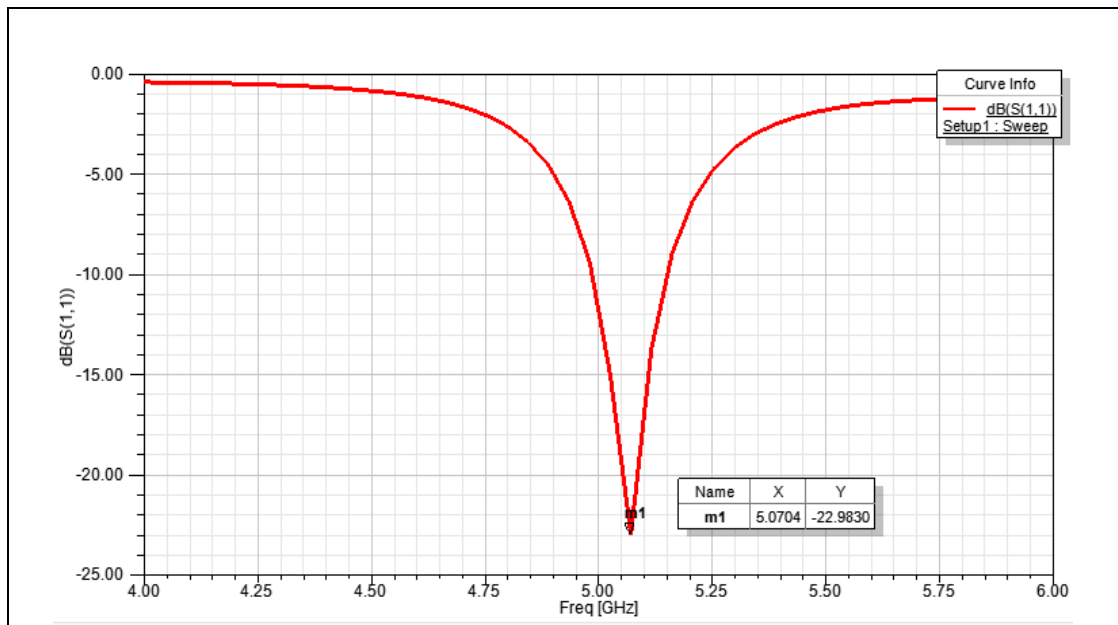

Fig.2: Return Loss Plot

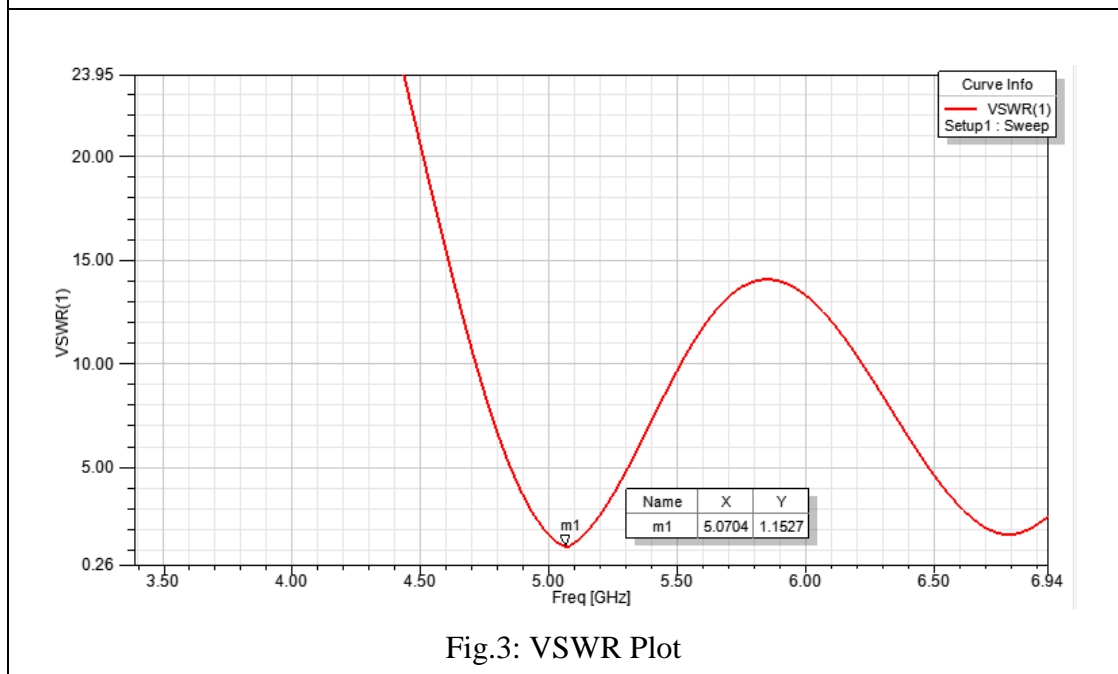
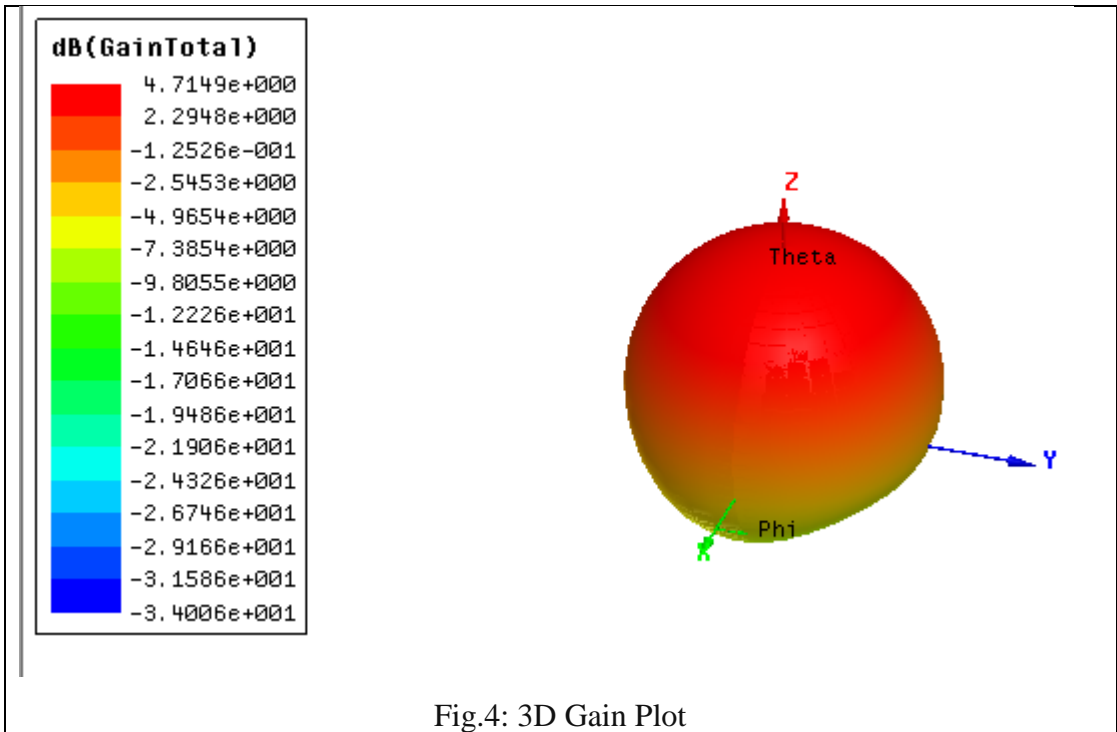

Fig.3: VSWR Plot



19. DESIGN OF MICROSTRIP TRIANGULAR PATCH ANTENNA USING CO-AXIAL FEED

AIM

Design and simulation of triangular patch antenna for 2.7GHz frequency using co-axial probe feeding.

APPARATUS

HFSS software version 13.0

THEORY

HFSS is a commercial finite element method solver for electromagnetic structures from ANSYS. ANSYS HFSS is a 3D electromagnetic simulation software for designing and simulating high frequency electronics products such as antennas, antenna arrays, RF or microwave components, high speed interconnects, filters, connectors, IC packages and printed circuit boards. Engineers worldwide use ANSYS HFSS to design high frequency, high speed electronics found in communications systems, radar systems, advanced driver assistance systems, satellites, internet of things (IOT) products and other high speed RF and digital devices.

ANSYS HFSS is the premier EM tool for R&D and virtual design prototyping. It reduces design cycle time and boosts your products reliability, and performance. HFSS is synonymous with gold standard accuracy and reliability for tracking 3D EM challenges by virtue of its automatic adaptive meshing technique and sophisticated solvers, which can be accelerated through high performance computing technology.

Microstrip antennas were first proposed in 1950's. The greatest interest in microstrip antennas, leading development and research started in 1950's.

- It is a metallic path placed on dielectric material and supported by ground plane.
- It could be easily fabricated on printed circuit board.
- It is most widely used antenna.
- Installation is very due to low size, weight, and cost.
-

There are two feeding methods for microstrip patch antenna

- Contacting Type
- Non-Contacting Type
-

In contacting type there are two methods

- Line feed microstrip
- Probe feed microstrip

In non-contacting type there are two methods

- Proximity feed microstrip
- Aperture feed microstrip

A Microstrip antenna consists of conducting patch on a ground plane separated by dielectric substrate which can be in various shapes as presented in the figure below

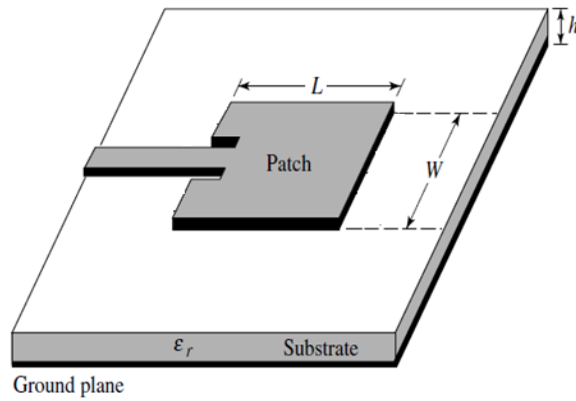

Fig.1: Microstrip Patch Antenna



Fig.2: Different shapes of patch

DESIGN VIEW

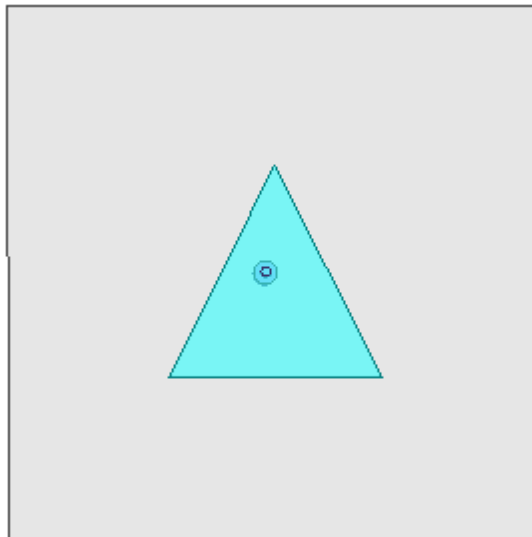
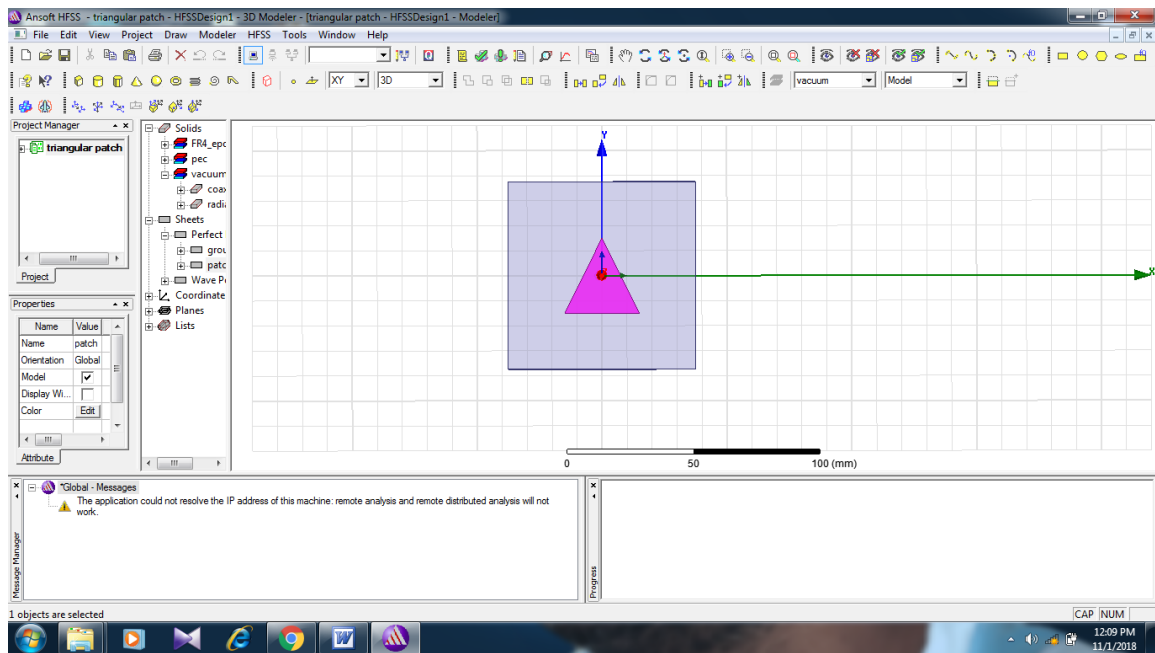

Fig.3: Triangular patch antenna using co-axial probe feeding.

PROCEDURE

- Insert new HFSS design
- Adjust the coordinate system.
- Create ground plane.
- Create a substrate with 1.6mm height.
- Create square patch with 30x30 dimensions on the substrate .
- Now click on polyline and draw two triangles on both the sides from center of the topside to the one end of bottom line.
- Now a main triangular patch is formed with small triangles on the adjacent sides.
- Now the adjacent triangles are subtracted from the main patch so that the required triangular patch is formed.
- Now make a hole on the ground plane according to the given dimensions.
- Insert co-axial cable with a certain height below the ground plane.
- Now insert the probe and pin with half of the radius.
- Now give the wave port feed at the closing circle of the bottom side of the co-axial.
- Now insert the radiation box above the ground plane and give excitation as perfect E to all sides of radiation box except the base side.
- Now give boundaries to ground plane and patch.
- Go to validation check, and analyze all and plot the return loss, VSWR, gain plot.

PRECAUTIONS

- Assign boundary conditions and excitations to the respective planes properly.
- The base of radiation box should not be given boundary condition.

RESULT

Designed and simulated a microstrip triangular patch antenna using co-axial feed and plotted the return loss, VSWR, gain plot.

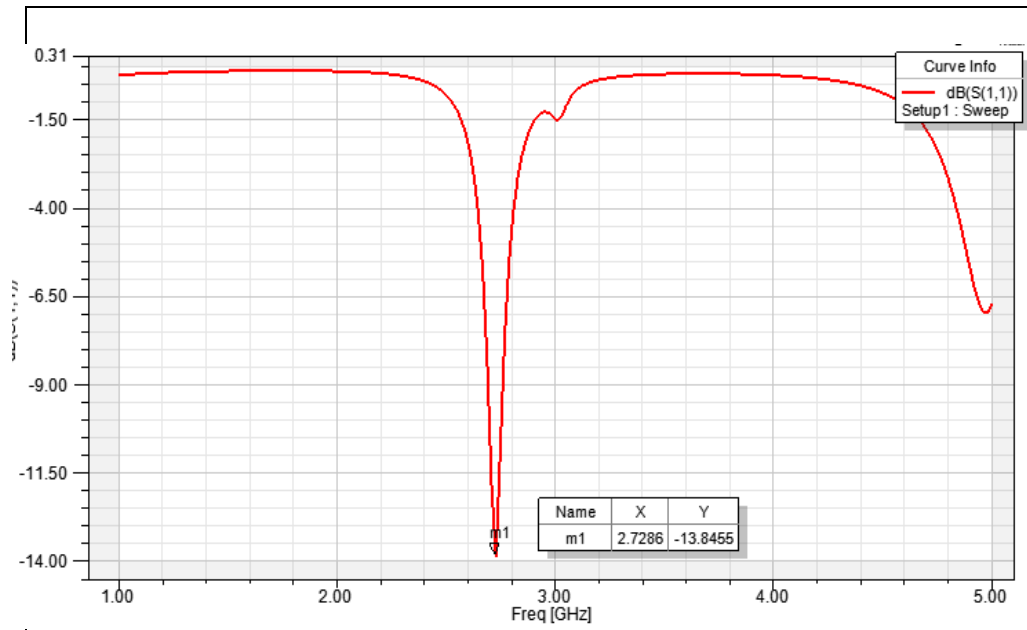

Fig.4:

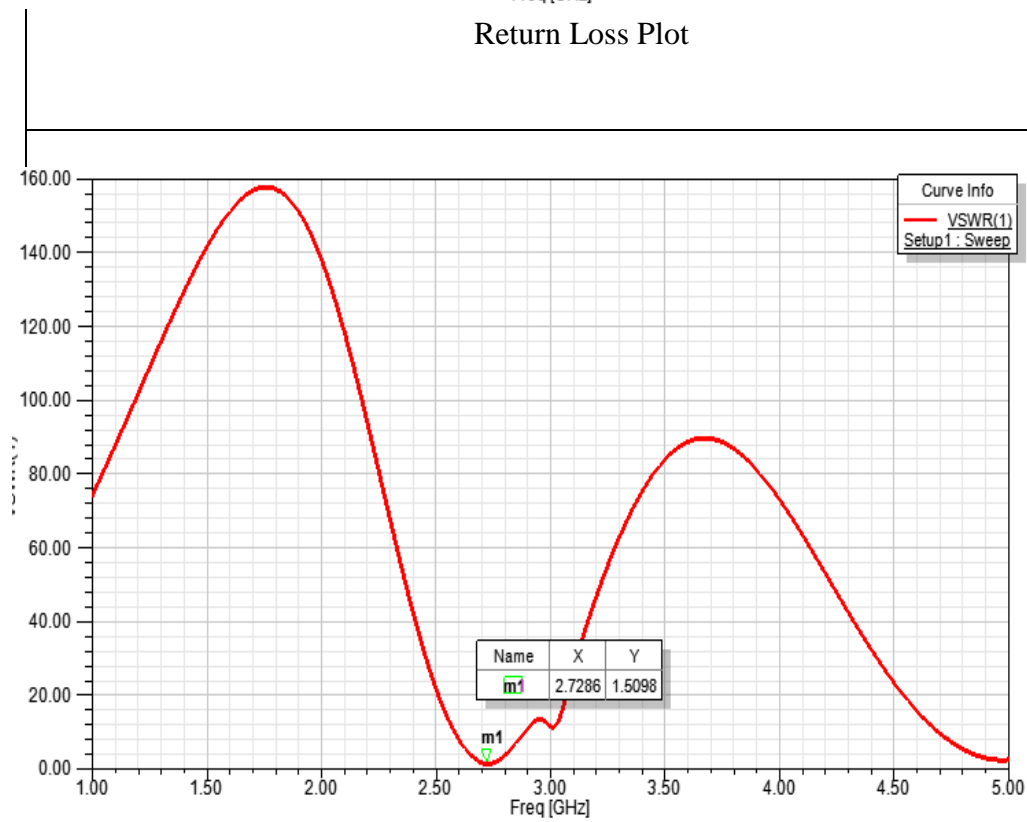
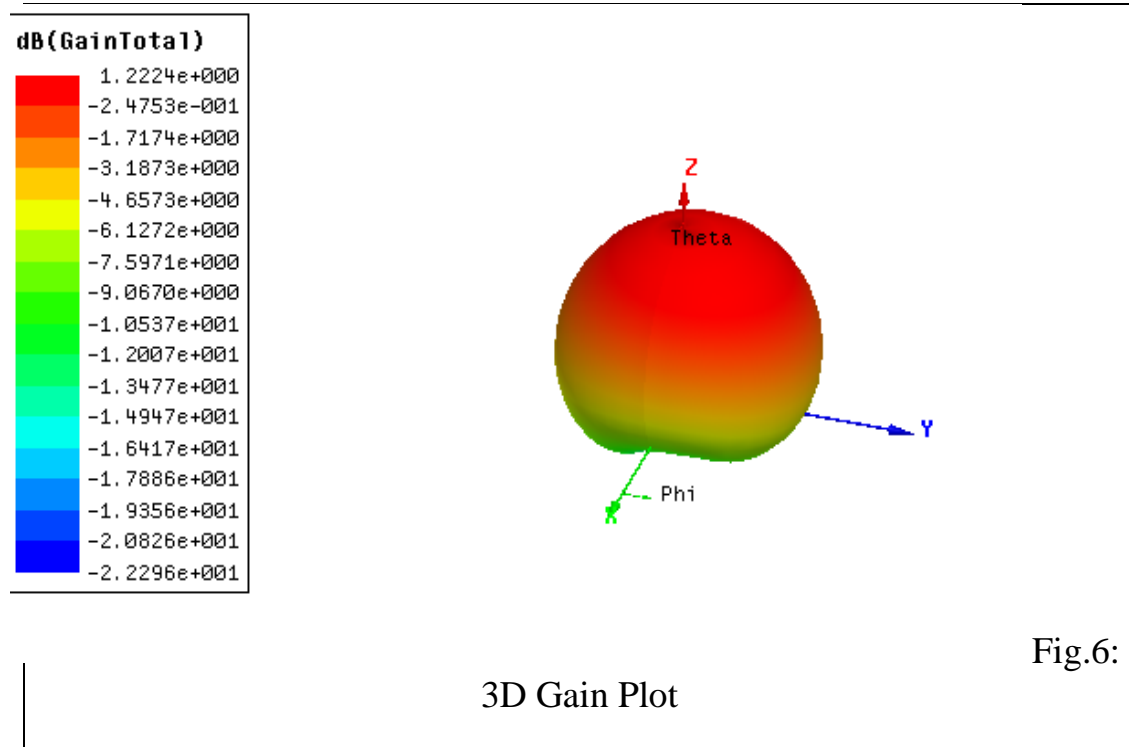

Fig.5:



VIVA QUESTIONS

1. Mention different types of the techniques used to feed the microstrip patch antenna and give the significance of each?
2. Mention the type of feeding that requires two substrates separated by a ground plane?
3. What are the different shape of the patch?
4. List the Pro and cons of using the microstrip patch antenna compared to conventional antenna
5. Mentions few application of patch antenna
6. What does FEM stands for?
7. What is the significance of cutting the slots in a radiating patch
8. What are the effect of the substrate on the band width of the antenna
9. What are fringing fields and what are its effect in case of the MSPA?

